



RETAIL POLICY
POLICY TO ALLOT AVAILABLE SPACES
AT MUMBAI METRO LINES 2A & 7 STATIONS
FOR RETAIL & OTHER COMMERCIAL USES

Policy No. MMMOCL/NFBR/Retail Policy/Oct-2023

September 2024

Maha Mumbai Metro Operation Corporation Limited (MMMOCL)
2nd Floor, NAMTTRI Building, Adjoining New MMRDA Building,
Bandra Kurla Complex, Bandra East, Mumbai 400051
www.mmmoocl.co.in

Disclaimer

All information provided as a part of this Policy to the prospective Interested Parties by Maha Mumbai Metro Operation Corporation Limited (MMMOCL) is subject to the terms and conditions as laid down in this document. The objective of this Policy document is to provide information to the interested entities about the commercial opportunity and to facilitate their Application for the same. MMOCL makes no representation or gives any warranty and shall incur no liability under any law, statute, rules or regulations as to the accuracy, reliability or completeness of this document. Interested Parties are advised to conduct their own assessment of the opportunity and obtain independent advice from appropriate sources as deemed necessary. MMOCL may, at their absolute discretion, and without being under any obligation to do so, update, amend or supplement the information in this document.

--- INTENTIONALLY LEFT BLANK ---

Table of Contents

SN	Description	Page No.
1	Definitions	4
2	Letter of Invitation	5
3	Objective of the Policy	6
4	About Mumbai Metro Line 2A & 7	7
5	Typical Station Design	11
6	Eligibility Criteria	18
7	Allotment Process	20
8	Application Procedure	21
9	Evaluation of Application	22
10	Key Commercial Terms	23
11	Provision for Licensing Space	29
12	Suspension & Termination	37
13	Other Terms	40
	<u>Annexures</u>	
1	Application Letter	42
2	Power of Attorney Format	44
3	Statutory Auditor Certificate	46
4	Indemnity Bond	47
5	Solvency Certificate	48
6	Inventory of Commercial Spaces Available	49
7	Draft License Agreement	63
8	Performance Bank Guarantee	85
9	Desing Guidelines	89

1. Definitions

Term	Definition
Authority	Maha Mumbai Metro Operation Corporation Ltd (MMMOCL)
Mumbai Metro Lines 2A & 7	Fully elevated metro lines being developed by MMOCL – Line 2A: Andheri West – Dahisar East Line 7: Ovaripada– Gundavali (Andheri East)
Retail Policy	Policy to Allot Available Spaces at Mumbai Metro Line 2A & 7 Stations for Retail & Other Commercial Uses
Applicant	Entity submitting Application for grant of License in accordance to this Policy
Application	Submissions by the Applicant towards this Policy
License	Rights to set-up and operate commercial spaces at metro stations on Mumbai Metro Lines 2A & 7 for retail & other commercial uses
Licensor / Authority	Maha Mumbai Metro Operation Corp Ltd (MMMOCL)
Licensee / Selected Entity	Appointed Applicant to whom License is granted post signing of the License Agreement
License Agreement	Contract between Licensee and Licensor wherein Licensor grants rights to Licensee to utilize allotted spaces at Mumbai Metro Lines 2A and 7 for retail or other commercial uses
License Period	Period for which the License is granted
Lock-in Period	Period for which the Licensee cannot terminate the License
License Fee	Consideration for grant of License to be paid for the License of spaces allotted under Retail Policy
Escalation	% increase in License Fee / other charges applied per annum
Performance Security	Bank Guarantee or Demand Draft furnished by the Licensee as security deposit against non-performance of Licensee's obligations

2. Letter of Invitation

Policy No: MMMOCL/NFBR/RetailPolicy/Oct-2023

Sub: : Letter of Invitation (LOI) for Applications from interested entities towards Policy to Allot Available Spaces at Mumbai Metro Lines 2A & 7 Stations for Retail & other Commercial Uses.

Dear Sir / Madam,

Maha Mumbai Metro Operation Corporation Limited (MMMOCL), a Government of Maharashtra Public Sector Undertaking (PSU), is in charge of operating and maintenance of the 35 km Mumbai Metro Lines 2A & 7 comprising of 30 fully elevated stations.

The purpose of this Policy is to allot available commercial spaces to eligible and interested parties for retail and other commercial uses at Mumbai Metro Lines 2A & 7 stations. The eligibility criteria, commercial terms and other provisions have been detailed out under various sections of this policy document. MMMOCL shall evaluate all Applications received and grant the License to the eligible Applicant as per the outcome of the evaluation of the Application by MMMOCL as detailed in this Policy

The Policy document shall be available for free download at the MMMOCL website. Further updates may be made to this Policy by MMMOCL from time to time, which shall be updated on the MMMOCL website.

For further details, you may contact:

Prashant Visoriya, Manager (Commercial)

Maha Mumbai Metro Operation Corporation Limited (MMMOCL)

2nd Floor, NAMTTRI Building, Adjoining New MMRDA Building,

Bandra Kurla Complex, Bandra East, Mumbai 400051

Phone: +91(22) 35001854

Email: mgco@mmmocl.co.in

Sincerely,

Sd-

Managing Director

September- XX, 2024 | Mumbai

3. Objective of this Policy

- 3.1 The Authority intends to monetize Available Spaces at Mumbai Metro Line 2A & 7 Stations for Retail & other Commercial Uses
- 3.2 The Authority has identified licensing spaces for retail and other commercial uses as one of the revenue heads for Non-Fare Box Revenue (NFBR) generation.
- 3.3 The purpose of this Policy is to select Licensee for Available Spaces at Mumbai Metro Line 2A & 7 Stations for Retail & other Commercial Uses for listed units.
- 3.4 Interested organizations may consider developing a transit-specific format as is the case at transit metro retail overseas, to tap this emerging and substantial opportunity over the coming decade.

-----INTENTIONALLY LEFT BLANK-----

4. About Mumbai Metro Line 2A & 7

4.1 Overview

4.1.1 Maha Mumbai Metro Operation Corp Ltd (MMMOCL) is a Government of Maharashtra Public Sector Undertaking (PSU), is in charge of operating and maintenance of the 35 km Mumbai Metro Lines 2A & 7 comprising of 30 fully elevated stations. Line 2A & 7 forms an integral part of the Mumbai Metro Master Plan as it provides unprecedented connectivity to Mumbai's business districts as well as major transport hubs in the city.

4.1.2 Mumbai Metro Line 2A

- Metro Line 2A from Andheri West to Dahisar East is 18.6 km long elevated corridor with 17 stations.
- Metro Line 2A shall provide connectivity for the western and northern suburbs of Mumbai along Link Road on the western side of the suburban railway line.

4.1.3 Mumbai Metro Line 7

- Metro Line 7 from Dahisar East to Andheri East is 16.5 km long elevated corridor with 13 stations.
- Metro Line 7 shall provide connectivity for the western and northern suburbs of Mumbai along Western Express Highway on the eastern side of the suburban railway line.

4.1.4 Project Schedule

- In the first phase, ~20 km of the stretch from Dahanukarwadi to Dahisar East on line 2A and Dahisar East to Aarey on line 7 has been commissioned in Apr'2022 and rest of the stretch was commissioned in Jan'2023, however, the viaduct for the entire stretch is in place for OFC installation.

Line	Stations	Km	Alignment	Alongside Road
Line 2A	17	18.6	Andheri West to Dahisar East	Link Road
Line 7	13	16.5	Dahisar East to Andheri East	Western Express Highway
Total	30	35		

4.2 Mumbai Metro Master Plan



Line 2A

Line 7

4.3 Alignment of the Metro Lines 2A & 7



4.4 Interchanges

4.4.1 Line 2A shall have interchange/proximity with –

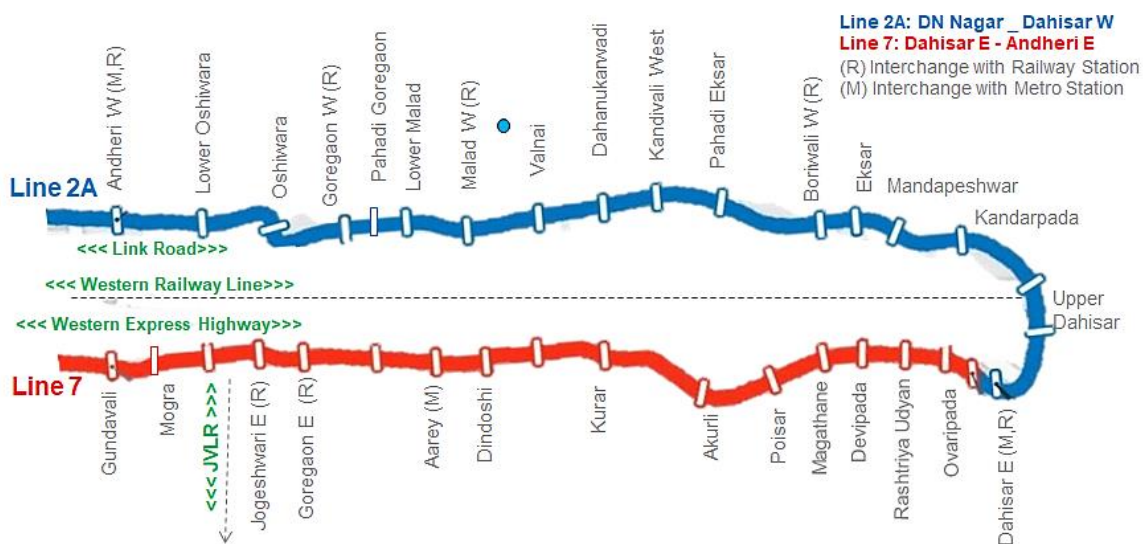
- a. Existing Metro Line 1 (Ghatkopar to Versova) at Andheri West
- b. Upcoming Metro Line 7 (Dahisar East to Andheri East) at Dahisar East
- c. Upcoming Metro Line 2B at Andheri (W)
- d. Metro Line 6 (Andheri West to Vikhroli) at Lower Oshiwara
- e. Upcoming metro Line 9 from Dahisar East to Mira Bhayandar
- f. Suburban rail at Andheri, Goregaon, Malad, Kandivali, Borivali and Dahisar

4.4.2 Line 7 shall have interchange/proximity with –

- a. Existing Metro Line 1 (Ghatkopar to Versova) at Andheri East at Western Express Highway (WEH) station.
- b. Upcoming Metro Line 2A (Andheri West to Dahisar East) at Dahisar East and 7A from Andheri to CSIA
- c. Metro Line 6 (Andheri West to Vikhroli) at Jogeshwari East
- d. Suburban rail at Jogeshwari and Goregaon

4.4.3 These interchanges/proximity will allow seamless rapid access to all parts of the city.

Line 2A & 7 interchanges/proximity with other transport hubs



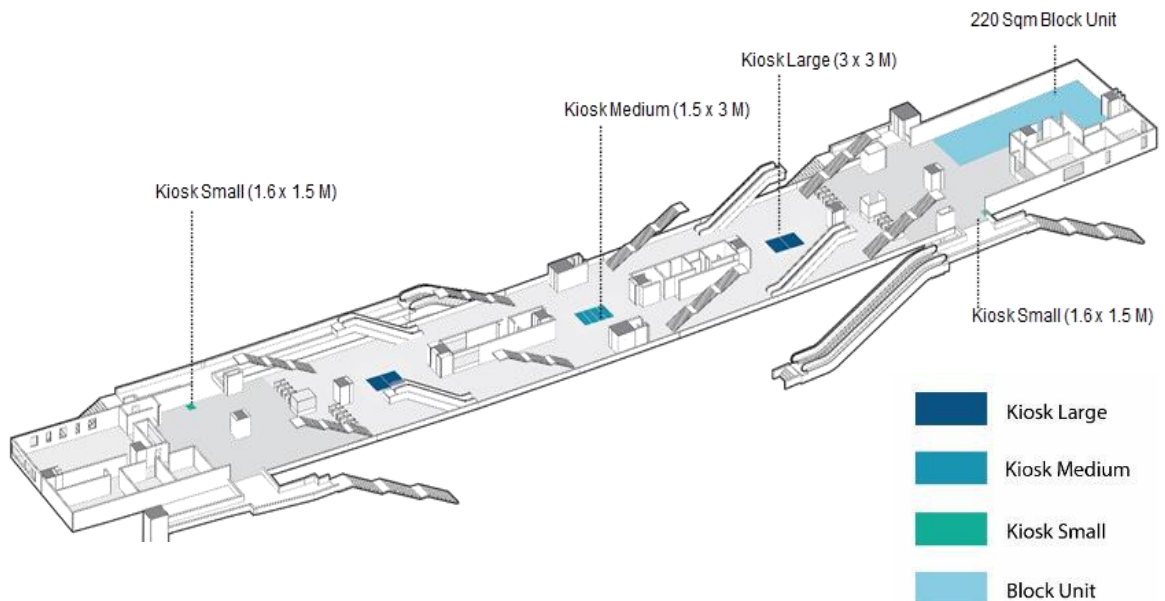
5. Typical Station Design

- 5.1 The metro stations are typically designed over two levels overground - concourse and platform.
- 5.2 Concourse level is typically located 7 metres above ground level and serves as the place where commuters shall arrive after taking the escalator / elevator or stairs from the ground level.
- 5.3 Concourse level is split into two parts - unpaid area and paid area.
 - Unpaid area is where the commuters shall land and is where commuters can purchase tickets from ticket vending windows and ticket vending machines.
 - Unpaid area is separated from the paid area located at the centre of the station box by the security gates and fare collection gates.
- 5.6 Both Unpaid and Paid area accommodates vertical circulation elements (lifts, escalators and stairs) which allow for connectivity between the street level to the concourse and further from the concourse to the platform.
- 5.7 The platform is typically located 16 metres above ground level and is typically 185 meters long and 24 meters wide and is planned with the track in the centre and platform on either side.
- 5.8 Along the platform are platform screen doors which screen the platform from the train for safety for commuters by reducing the likelihood of accidents.

Typical Station Cross Section

Level Zero	Ground level (at-grade) which will have station entry / exits
Level One	Concourse level which will have the ticketing area and the access points to go to the platform
Level Two	Platform level from where passengers can board the metro

Line 2A Indicative Retail Layout

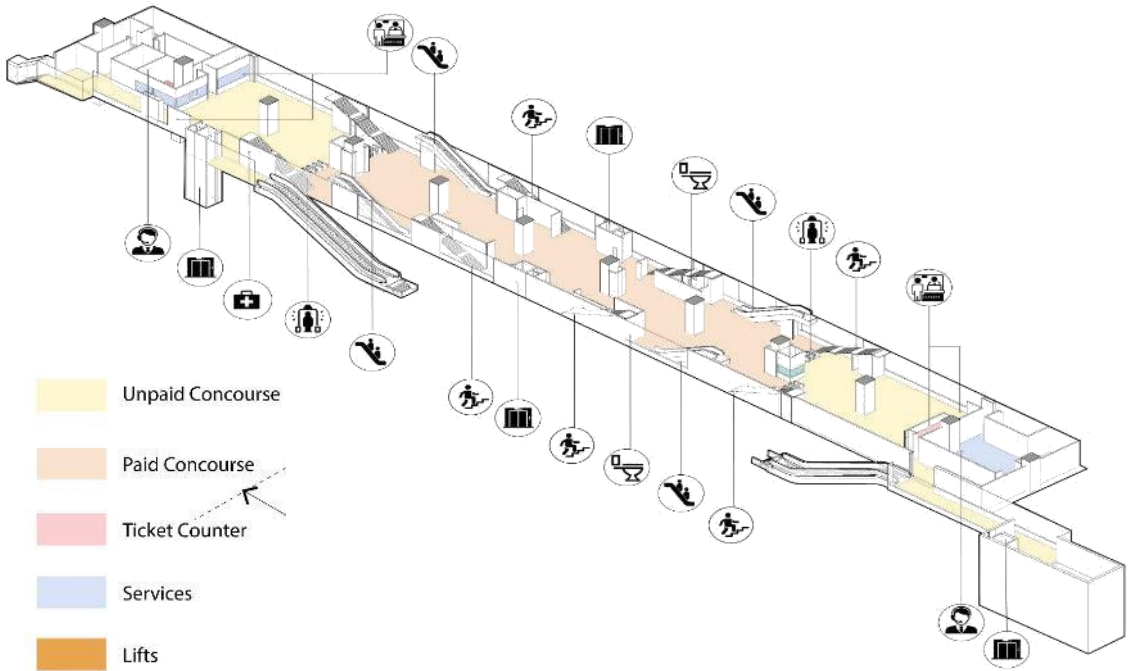


* Few stations on this line may be exception to this typical layout

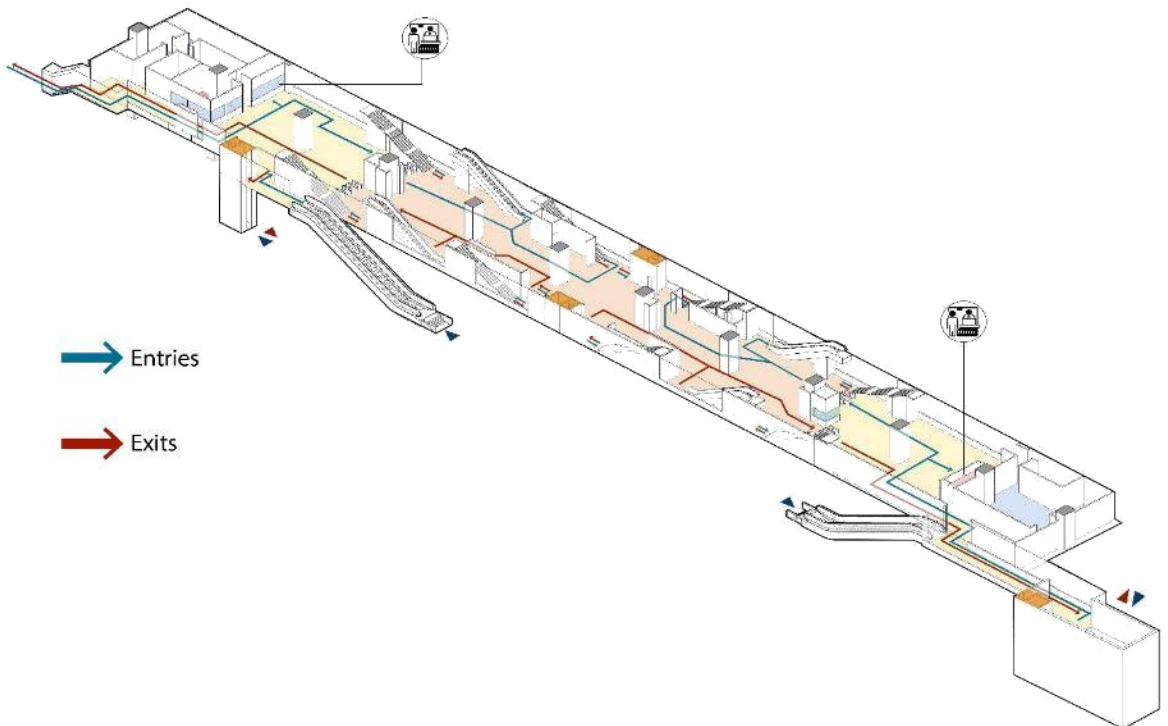
Please note –

- If feasible Electricity shall be provided for both kiosks and blocks
- Water and drainage shall be provided for blocks only
- Water and drainage point shall be provided at one end of the block and the concessionaire shall have to make arrangement to draw it till the units
- All station layouts and list of space units available is published in the Annexure

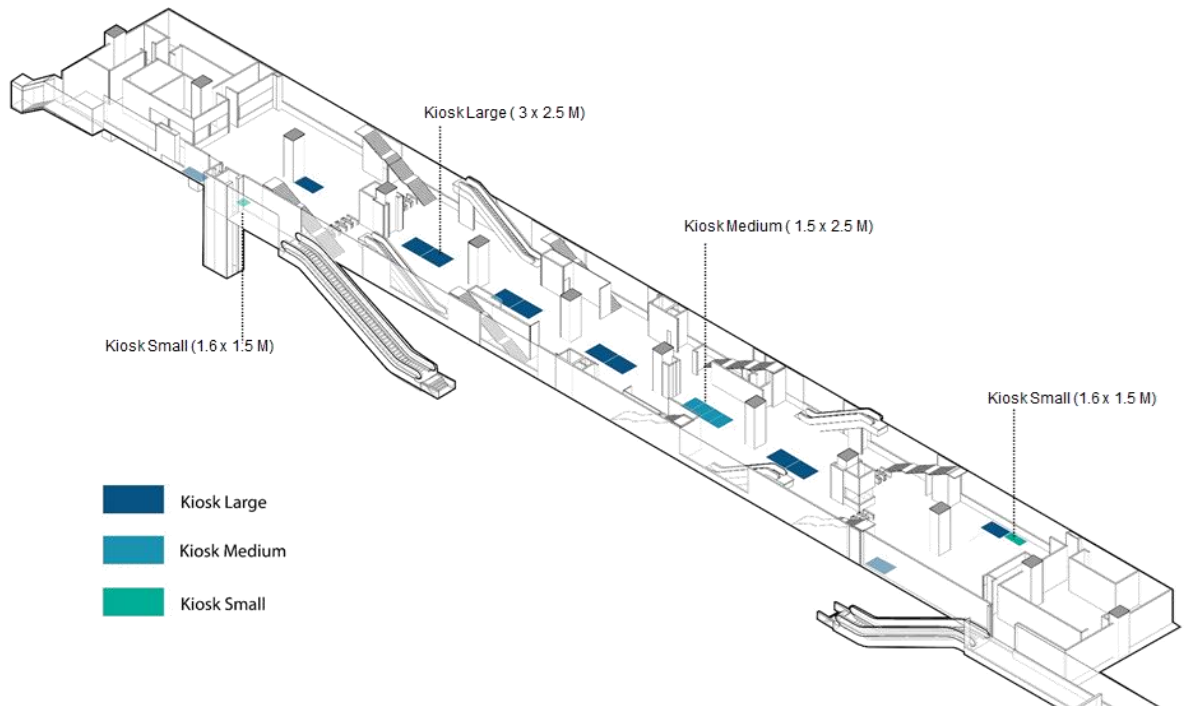
Line 7 Concourse Level Layout



Passenger Flow



Line 7 Indicative Retail Layout

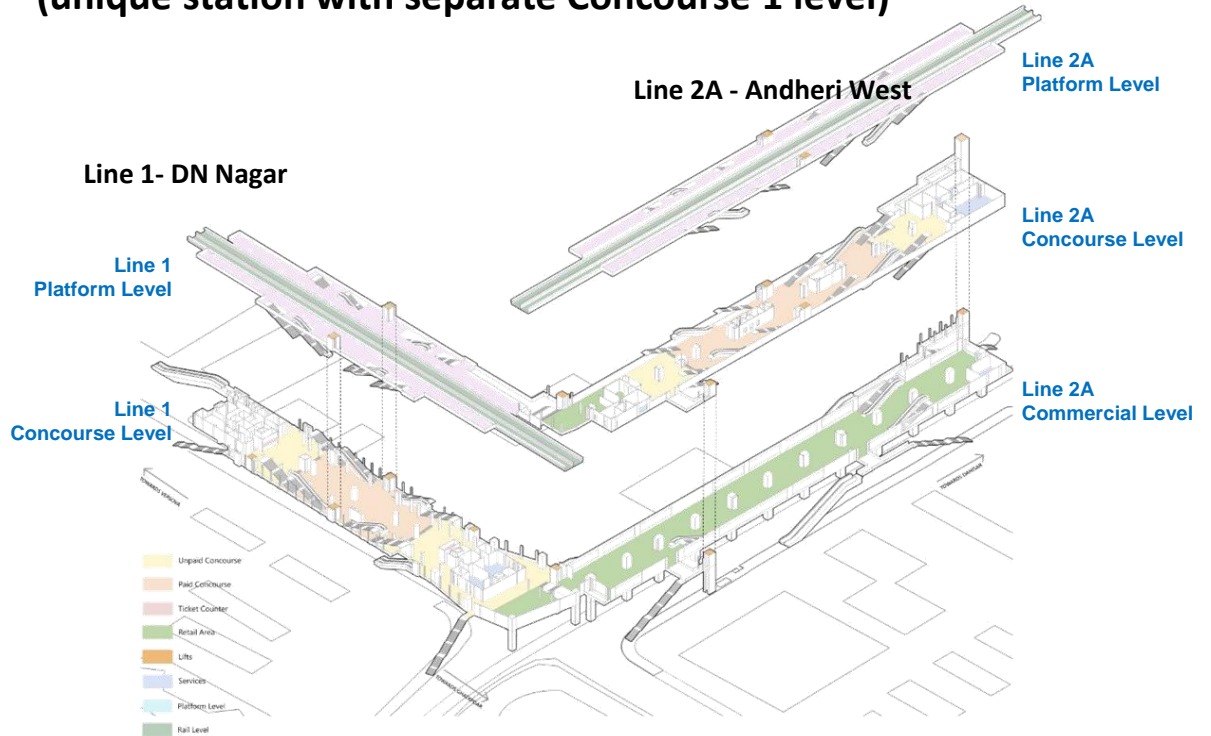


* Few stations on this line may be exception to this typical layout

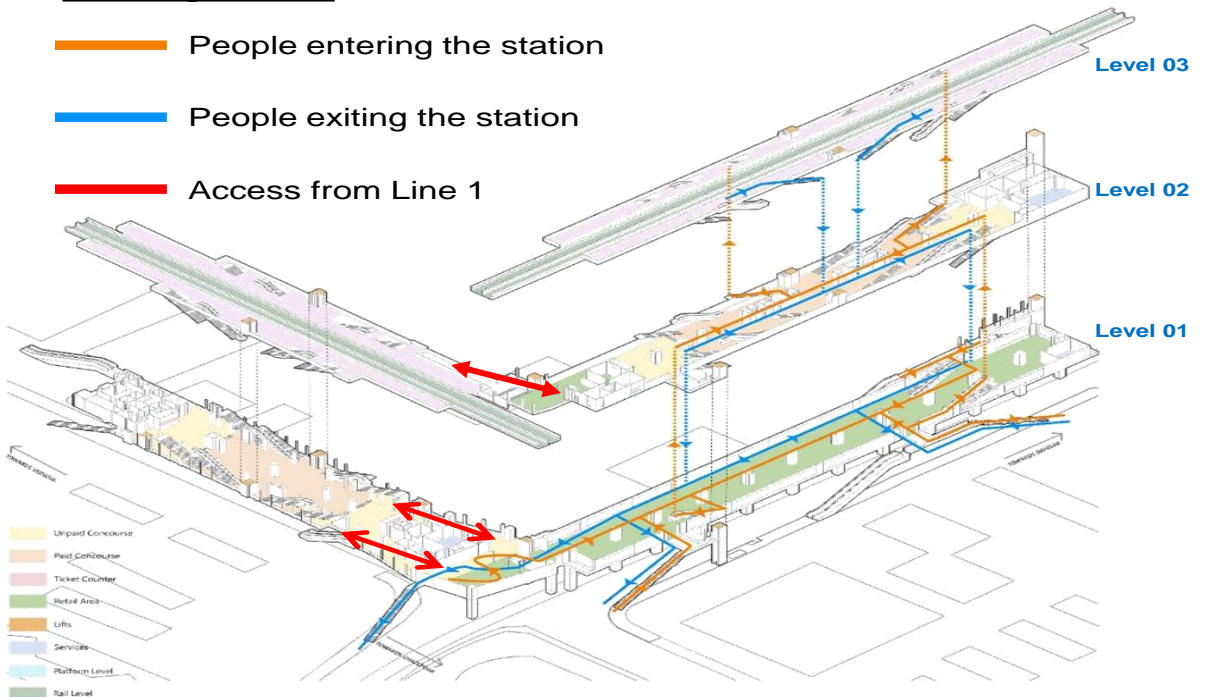
Please note –

- If feasible Electricity shall be provided for both kiosks and blocks
- Water and drainage shall be provided for blocks only which are not present at Line 7
- All station layouts and list of space units available is published in the Annexure

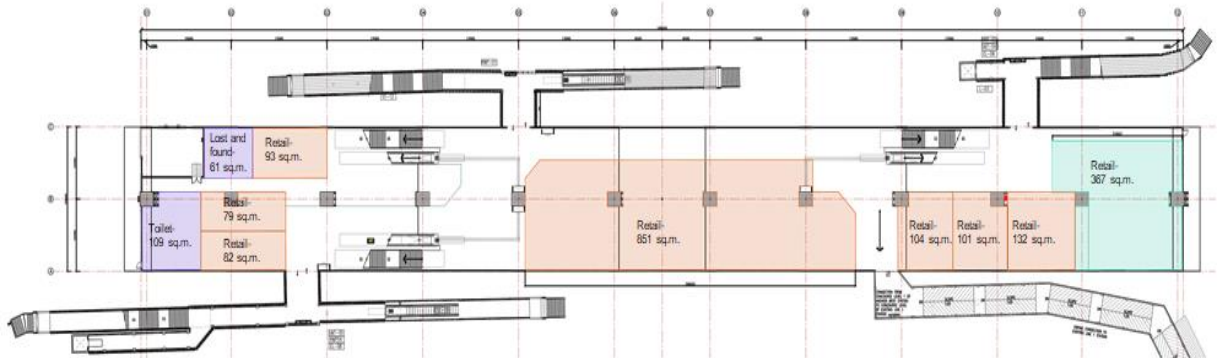
Line 2A Andheri West Metro Station Indicative Retail Layout (unique station with separate Concourse 1 level)



Passenger Flow



Andheri West Indicative Retail Layout



* Detailed layout in the enclosures

Please note –

- Electricity, if feasible data, water, drainage shall be provided for both kiosks and blocks on this level
- Electricity and data connectivity shall be as drop down from false ceiling
- Water and drainage points shall be provided at the corners of the floor plate and the concessionaires shall have to make arrangement to draw them till their units
- All station layouts and list of space units available is published in the Annexure

6. Eligibility Criteria

- 6.1 The Applicant shall be a sole proprietary firm, partnership firm or a company incorporated under the Companies Act 1956 / 2013 or equivalent laws in the country of incorporation.
- 6.2 Applicant should have a valid PAN, TAN, GST registration as applicable. Relevant registration certificates to be submitted.
- 6.3 Applicant is required to meet the Technical and Financial Eligibility Criteria as prescribed in this document.
- 6.3 Applicant should not have been debarred from participating in tenders with any of the following authorities:
 - a. MMMOCL or any other Metro / Railway Organization in India
 - b. Any Planning Authority in Maharashtra including MMRDA, MCGM, etc.
 - c. Any Central or State Ministry or Department in India
 - d. The Applicant shall make this declaration in its Application Letter as per the prescribed format
 - e. In case at a subsequent date, the successful Applicant is found to be debarred, MMMOCL shall have full rights to terminate the License or disqualify for this policy as applicable. In such cases, Bid Security / Performance Security furnished by the Applicant / Licensee shall be forfeited.

Key Term	Description
Eligibility Criteria	Documentary Proof Acceptable
Technical Eligibility Criteria	<ul style="list-style-type: none"> ▪ Minimum 3 years of experience in managing any business for Applicants applying for Blocks or more than 1 Kiosks ▪ No such criteria for Applicants applying for 1 kiosk <ul style="list-style-type: none"> • For companies incorporated in India, Certificate of Incorporation/ Registration under Companies Act 1956 / 2013 or Partnership Firm registered under the LLP Act • For foreign firms, equivalent certificate in the country of Incorporation
Financial Eligibility Criteria	<p>Minimum Average Annual Turnover over last 3 financial years should be –</p> <ul style="list-style-type: none"> ▪ Rs 1 Cr if applying for Blocks or > 10 Kiosks ▪ Rs 10 lakh if applying for 2-10 Kiosks ▪ No minimum turnover if applying for 1 Kiosks <ul style="list-style-type: none"> • Audited financial statements for preceding three financial years • Statutory Auditor / Chartered Accountant certificate certifying the average turnover • The above documents have to be submitted by the Applicant irrespective of the number of kiosks / blocks applied for
Consortium or Joint Ventures (JV)	Consortium or JV are not permitted

7. Allotment Process

- 7.1 MMMOCL has published this Policy along with the list of available commercial units on its website www.mmmoocl.co.in.
- 7.2 MMMOCL shall published updated list of units available along with the Base Price every 2 months.
- 7.3 Application window is available every 2 months for a period of 2 weeks in which the list of inventory is published.
- 7.4 Applicant may apply for 1 or more units at any of the stations mentioned in the inventory list. In case of Blocks, Applicant may apply for part of the Block subject to a minimum of 500 sqft and MMMOCL may allot such units based on their assessment of feasibility of the entire space available at its discretion on a case-to-case basis.
- 7.5 Applicant may apply for units at or above the Base Price mentioned in the inventory list.
- 7.6 Applicant is advised to undertake site visits and carry out their detailed due diligence of the commercial opportunity and of the information contained in this document. MMMOCL shall facilitate such site visits.
- 7.7 MMMOCL may revise the number of units available, size and location of the units, Base Price, etc. subsequently. MMMOCL may add additional units to the list basis availability and feasibility.
- 7.8 MMMOCL shall endeavour to respond to / approve the Application within 2 weeks of submission.

8. Application Procedure

- 8.1 The Applicant shall make a request on its letter head in the Application format specified in the Annexure via physical letter and email.
- 8.2 The Applicant shall bear all costs associated with the preparation and submission of its Application and subsequent correspondences, and the Authority shall not be liable for those costs, regardless of the conduct or outcome of the evaluation process.
- 8.3 The Applicant shall be required to submit the Application along with non-refundable Application fees of Rs. 10,000/- (Rupees ten thousand only) in the form of Bankers Cheque/ Demand Draft drawn in favour of Maha Mumbai Metro Operation Corporation Limited payable at Mumbai.
- 8.4 Applicant is required to submit their Application towards this Policy in the format prescribed in this document within the prescribed timelines in both hard copy and soft copy format. Hard copy to be submitted to MMMOCL address mentioned in this document and soft copy to be emailed to mgco@mmmocl.co.in.
- 8.5 The Application form along with required documents as specified in the Policy shall be sent to the following address: c/o Manager Commercial , Maha Mumbai Metro Operation Corporation Limited, 2nd Floor, NaMTTRI Building, Plot No. R-13, E-Block, Bandra Kurla Complex, Bandra East, Mumbai 400051, Email: mgco@mmmocl.co.in
- 8.3 Application shall be signed by the Authorized Signatory of the Applicant.
- 8.4 Any queries pertaining to the Policy document shall also be sent at the above address.
- 8.5 The Application and all the related correspondence and documents shall be written in English language only.
- 8.6 Application must remain valid for 180 days from the last date of Application submission as per this Policy.
- 8.7 The Authority will make its best effort to complete the negotiations within the Application's validity period, however, should the need arise, the Authority may request, in writing, all Applicants who submitted Applications prior to the submission deadline to extend the Application's validity.
- 8.8 If the Applicant agrees to extend the validity of its Application, it shall be done without any change in the original Application.
- 8.9 The Applicant has the right to refuse to extend the validity of its Application in which case such Application will not be further evaluated.

9. Evaluation of Application

- 9.1 The Authority's will nominated the evaluation committee which consist of 1 each Nominated Officer from Finance and Commercial department. Evaluation committee shall evaluate the Application along with all the requisite documents.
- 9.2 Conditional Applications shall be rejected outright by the Authority.
- 9.3 The Applicant which has submitted the highest License Fee for a unit shall be allotted the unit. In case of a tie, then allotment will done from lottery system.
- 9.4 Further, in the event of the Appointed Party withdrawing its Application, the Authority without being under any obligation to do so, may at its sole discretion, blacklist the Appointed Party which has withdrawn its Application.
- 9.5 The Authority reserves the right to reject any/all Applications or withdraw the Policy at any stage without assigning any reasons whatsoever. Nothing contained herein shall confer a right upon an Applicant or any obligation upon the Authority.
- 9.6 The Applicant hereby voluntarily and unequivocally agrees that the Authority shall not be under any obligation or be liable for any acceptance, rejection or annulment of any/all Applications and the Applicant shall not seek any claims, damages, compensation or any other consideration whatsoever on this account, from the Authority.
- 9.7 Penal Action:
 - i. The Appointed Applicant after grant of License shall perform its obligations under the License Agreement by adhering to the terms and conditions set forth therein, failing which it shall be construed upon as the Licensee has defaulted in honouring contractual obligations and the defaulting Licensee after termination of the License Agreement shall thus be liable for penal action so as to debar the defaulting Licensee from having dealing with the Authority either permanently or for the period as shall be decided by the Authority.
 - ii. The penal action shall be without prejudice to the rights and remedies available to the Authority and also be in addition to the action to be instituted against the defaulting Licensee under other terms and conditions of the License Agreement.

10. Key Commercial Terms

Key Terms	Description
Contract Type	<ul style="list-style-type: none"> License Agreement between Licensor (MMMOCL) and Licensee (Selected Applicant)
Unit area available for Commercial Use	<ul style="list-style-type: none"> Kiosks up to 500 sqft area Blocks > 500 sqft area
List of units available for commercial use	<ul style="list-style-type: none"> MMMOCL shall publish a list of available inventory periodically; and MMOCL shall have the discretion to reconfigure the units in every subsequent published list
License Period	<ul style="list-style-type: none"> 5 (Five) Years extendible by another 5 (five) years for Kiosks 8 (Eight) Years extendible by another 5 (five) years for Blocks License Period shall start from the date of signing of the License Agreement
Lock-In Period	<ul style="list-style-type: none"> 1 Year for Kiosks, 2 Years for Blocks from the date of starting of Licence Fee period
Notice Period for surrender	<ul style="list-style-type: none"> 6 months' notice period from the date of intimation, subject to Lock-In Period. (Notice period can be given only after Lock-In period)
Extension Period	<ul style="list-style-type: none"> At the time of Expiry of License, the Authority shall have the discretion to extend the period by another 5 years at the License Terms decided by the Authority at that time, provided that the Licensee has met its obligations throughout the License Period to the satisfaction of the Authority
Pre-Commencement Period	<ul style="list-style-type: none"> 60 days from signing of the License Agreement License Fee is not payable for such period This period shall be used by the Licensee strictly for installation of fixtures and setting up operations; no revenue operations shall be allowed in this period License Fee shall be payable from the expiry of the Pre-Commencement Period or actual start of revenue operations of the Block / Kiosk, whichever is earlier
Sub-Licensing	<ul style="list-style-type: none"> Permitted; Licensee can monetize the Commercial Space through Sub-License contracts with interested parties

Key Terms	Description
Costs involved	<ul style="list-style-type: none"> • The Licensee shall be required to incur following costs during the License Term: <ul style="list-style-type: none"> • All installation & operations cost • License Fee, Common Area Maintenance Charges if any, and Performance Security • Installation of electricity meters, electricity charges on actuals as applicable • Cost of cabling, clamps, and all other material required for installation and operations • Applicable taxes including GST and stamp duty, all Statutory levies as applicable, Insurance Premium for equipment, if any
Electricity & Utilities	<ul style="list-style-type: none"> • Separate meter shall be procured and installed by the Licensee in its own name based on the recommendation by the Authority of the Electricity Distribution Company (Discom) or MMMOCL will provide the connection at common point from there Licensee will lay the cable up to the kiosk/Block at his own cost • Licensee shall be responsible to co-ordinate all the power supply related arrangements • Utility charges for electricity to be paid directly by the Licensee to the Discom • Licensee shall be responsible to make provisions on its own for their earthing requirements.
Implementation Plan	<ul style="list-style-type: none"> • Licensee is required to prepare the Implementation Plan within 15 days of issue of LOA and submit to MMMOCL for approval • MMMOCL will respond to the plan within 15 days of submission • If there is a delay on part of MMMOCL to revert to the plan, then there will be commensurate adjustment to the Pre-Commencement Period • However, if there is any delay on part of the Licensee, then there will be no such adjustment of Pre-Commencement Period • Implementation Plan should include detailed architectural drawing of the kiosk / block including details of material used, electrical and other utility connections, fire extinguisher and sprinkler locations, etc. • Manager (Commercial) and / or Assistant Manager (Business Development) shall consult with the relevant officials at MMMOCL and its consultants if any, and provide the comments / approval to the Implementation Plan

Key Terms	Description
Revenue Model	<ul style="list-style-type: none"> • Fixed Rent / License Fee per unit per month payable by the Licensee as per the prescribed payment terms • No Revenue Sharing envisaged
Quote Parameter	<ul style="list-style-type: none"> • Applicants are required to Quote a lumpsum Rs per month (rounded off to the nearest Rupee) for each unit which they are applying for
Payment Terms	<ul style="list-style-type: none"> • License Fee payable quarterly in advance. • License Fees shall be escalated annually by 5% per year on previous year rental. • First invoice to be raised 30 days prior to the expiry of the Pre-Commencement Period • For subsequent quarters, the Authority will raise the invoice 1 month prior to the start of the quarter • Invoice shall be raised by 1st of the month payable by 30th of the same month. For e.g., for the Quarter starting from 1-April-2024 to 30-June-2024, Invoice will be raised on 1-March-2024 and same will be payable by 30-March-2024 • Licensee shall pay Common Area Maintenance (CAM) charge of Rs 5 per sqft per month (on quarterly basis) along with the License Fees which shall be escalated annually by 5% as detailed hereinabove. Garbage disposal of Kiosk/Block is responsibility of the Licensee • Utility charges for water, electricity etc., if any, to be billed on actuals on Quarterly basis along with the License Fee payable within the prescribed date
Performance Security	<ul style="list-style-type: none"> • Interest Free Performance Security to be furnished for an amount equal to 6-months License Fee for a validity of 12 months. • Performance Security can be furnished in the form of a Demand Draft or Bankers Cheque or Bank Guarantee (BG). • The Licensee shall, 2 weeks prior to the expiry of the Performance Security, extend it by 12 months and augment the BG / furnish additional Demand Draft equal to 6-months License Fee of the subsequent year (adjusted for 5% escalation), till the end of the License Period. • Failure to furnish the initial or subsequent Performance Security shall attract Cure Period clauses as specified in this Policy; if the BG is still not furnished within the Cure Period, then it shall be an Event of Default and shall lead to initiation of termination proceedings.

10.1 Timelines

- 10.1.1 The follow timelines are required to be followed by the Licensee
- 10.1.2 MMMOCL shall not entertain any requests for delay in meeting these timelines on the part of the Licensee
- 10.1.3 MMMOCL shall provide commensurate extension of the Pre-Commencement Period for any delay in providing comments / approving the Implementation Plan

Timeline	Activity
L	Issue of Letter of Allotment (LOA) to the Selected Applicant
L + 7 days	Acceptance of LOA by the Applicant
L + 15 days	Furnishing of Performance Security (BG / DD)
A = L + 30 days	Signing of the License Agreement Start of the License Period Licensee to procure 2 nos. of stamp papers of Rs 500 each, print the draft agreement on it, sign and stamp the same and submit it to MMMOCL for countersigning; post that Licensee to get the agreement notarized and 1 original copy shall be retained by MMMOCL and the other copy shall be retained by the Licensee
L + 30 days	Licensee to submit the Implementation Plan within 15 days issue of LOA MMMOCL shall provide comments / approve the plan within 15 days from date of receipt of the detail plan as mentioned in this document
A + 60 days	Pre-Commencement Period <ul style="list-style-type: none"> License Fee is not payable for this period . This period shall be used by the Licensee strictly for installation of fixtures and setting up operations; no revenue operations shall be allowed in this period License Fee shall be payable from the expiry of the Pre-Commencement Period or actual start of revenue operations of the Block / Kiosk, whichever is earlier (Invoice shall be raised 1 month prior to the expiry of the Pre-Commencement Period)
A + 1 year	Lock-In Period – Kiosk
A + 2 year	Lock-In Period – Blocks
A + 5 / 8 years	License Period for Kiosk/Block

10.2 License Period

- 10.2.1 The License Period shall be from the signing of the agreement as per Summary of Key Commercial Terms, unless otherwise terminated by the Authority or surrendered by the Licensee.
- 10.2.2 Lock-in Period shall be from the date of commencement of the License Period as per Summary of Key Commercial Terms.
- 10.2.3 Pre-commencement time period is available to the Licensee as per Key Commercial Terms to design and install the infrastructure will not be counted as part of the License Period.
- 10.2.4 Any extension of area of the allotted Kiosk / Block, if allotted by the Authority, shall be on pro-rata basis, subject to the Authority's approval.
- 10.2.5 The License Period for any such extended space handed over / allotted during the License Period will be co-terminus with the original License Period of the License Agreement.

10.3 License Fee

- 10.3.1 The Licensee shall, in consideration of the License granted by the Authority, pay to the Authority Licensee Fee and furnish Performance Security as detailed in the Summary of Key Commercial Terms.
- 10.3.2 The payment of License Fee to the Authority by the Licensee shall be completed by the Due Date as per Summary of Key Commercial Terms failing which interest at the rate of 12% per annum shall be charged for a period of 30 days and 18% per annum thereafter.
- 10.3.3 In case, default persists on the 31st day counted from due date, the Authority shall issue a notice of intent to terminate the License.
- 10.3.4 After expiry of Termination notice period of 30 days, if the default still persists, the Authority shall have the right to terminate the License forthwith or grant the Licensee further extension in case of exceptional circumstances subject to the Authority's assessment.

10.4 Performance Security

- 10.4.1 At the time of signing the License Agreement, the Selected Entity shall furnish Interest Free Performance Security to the Authority. Licensee shall furnish single Performance Security for all the units Licensed to it.
- 10.4.2 It shall be an irrevocable Bank Guarantee (BG) issued by a Nationalized or Commercial Bank or Demand Draft payable at branches of the said bank located in Mumbai.
- 10.4.3 In case the Licensee fails to furnish the prescribed BG/ Demand Draft from time to time, the Authority shall issue a notice with a 15-day cure period; if the Licensee still fails to furnish the BG/ Demand Draft within the cure period, then the Authority shall have the right to terminate the License and Licensee shall forfeit the Performance Security and License Fee paid in advance.

10.5 Other Payables

- 10.5.1 All statutory taxes including GST, municipal and other levies, insurance premium, as applicable to this License shall be billed by the Authority to the Licensee and shall be paid along with the License Fee for onward remittance to the relevant government authorities.
- 10.5.2 The Licensee shall save the Authority harmless from liability for any dues against the above; the Licensee indemnifies the Authority from any claims that may arise from the statutory authorities in connection with this License.
- 10.5.3 Payment of stamp duty for execution of License Agreement shall be borne by Licensee post adjudication.
- 10.5.4 The Licensee shall solely bear the cost of installation, operations, repair and maintenance of all fixtures installed at the units awarded.
- 10.5.5 Utility charges for electricity, data and water shall be billed by the Authority to the Licensee as per Summary of Key Commercial Terms.
- 10.5.6 Direct taxes on respective income shall be borne by the respective Parties.

11. Provisions for Licensing Space

11.1 Activities Permitted

11.1.1 Except for the activities banned by law or government regulations, the licensed spaces can be used for any of the following purposes –

- a. Food & Beverage: kiosks, stalls, food courts, etc.
- b. Product retail: convenience stores, supermarkets, pharmacy, bookstores, florists, speciality stores for sports, toys, fashion, etc.
- c. Service retail: salons, coaching classes, gyms, mobile top-up stores, etc.
- d. Office: bank branches, coworking spaces, courier centres, etc.
- e. E-commerce pickup points
- f. ATMs, Vending machines
- g. Any other commercial categories

11.1.2 The Licensee shall ensure proper storage of the packaged products ensuring that there is no contamination or decay.

11.2 Activities Not Permitted

11.2.1 Any product / service the sale of which is unlawful / illegal or deemed unlawful under any Indian act or legislation

11.2.2 Any product, the storage and sale of which may lead to or be considered as a fire hazard, such as firecrackers, industrial explosives, chemicals, etc.

11.2.3 Open sale of alcohol, tobacco and tobacco products is not permitted to discourage consumption at the metro stations / trains, however selling of the same in enclosed packets for pickup only shall be permitted

11.2.4 Use of open flame for cooking or any other purposes

11.2.5 Licensee shall ensure that activities undertaken at the licensed spaces neither interferes with metro activities nor causes inconvenience to commuters

11.2.6 In case the activities in the licensed spaces are found to interfere / infringe with metro activities or commuter movement, the Authority reserves the right to direct the Licensee not to undertake such activities any further at any stage during the License Period

11.2.7 The decision of the Authority in this regard shall be final and binding upon the Licensee and the Licensee shall not claim any loss or damages in this regard

11.3 Right to Sub-License

- 11.3.1 The Licensee shall be entitled to sub-license the licensed space to any person or entity after prior approval of the Authority (the 'Sub-Licensee'). However, all liabilities under the License Agreement will remain with the Licensee.
- 11.3.2 The sub-license shall be in effect only during the subsistence of the License Period, with a clear stipulation that all such sub-licenses granted shall be at maximum co-terminus with the License Period.
- 11.3.3 All contracts, agreements or arrangements with Sub-Licensee shall specifically stipulate this covenant of termination of the rights of the Sub-Licensees, and further that such Sub-Licensee shall not have any claim or seek any compensation from the Authority for such termination.

11.4 General Provisions for the Licensed Spaces

- 11.4.1 The Authority shall provide the Licensee with plain tiled flooring on "as is where is basis" without any structure or fixing arrangement.
- 11.4.2 The licensed space is located at Concourse and Concourse 1 levels within the stations; no such space is available at the platform level.
- 11.4.3 The licensed space is required to be refurbished / developed by the Licensee.
- 11.4.4 The Licensee shall submit all layouts, designs, proposed uses, specification of materials including but not limited to construction, internal partitions, fire detection & fighting, flooring, lighting, electrical, signages, advertisement panels, etc. in-line with the design guidelines specified in the Annexures and the same shall be sent for approval to the Authority before start of any works at the station.
- 11.4.5 The Authority reserves the right not to give approval if it deems that such works may act as hindrance in smooth functioning of its operations at the station.
- 11.4.6 The Licensee shall procure and install fixtures in consultation with the Authority without damaging the station structures, utilities or finishes; in case of damage the Authority will recover the cost from the Licensee.
- 11.4.7 All materials used, including electrical material, should be fire resistant as per the prescribed design guidelines given in the Annexures, and in this connection the approval of the Authority must be taken before commencement of installation.

- 11.4.8 The Licensee shall be required to execute all works as required for the commercial use in the licensed spaces without damaging any load bearing structures or services / utilities, etc.
- 11.4.9 The Licensee shall have to carry out all internal finishing works including internal partitions, utilities, doors, plastering, painting, etc. as per the design guideline given in the Annexures.
- 11.4.10 All necessary modification shall be carried out by the Licensee at its own cost after taking approval of the plans from the Authority; if there is any damage to any structure / asset of the Authority, the cost shall be borne by the Licensee.
- 11.4.11 The Licensee shall be solely responsible for procuring all the permissions / licenses / NOCs, Insurance cover, etc. required from the statutory / regulatory / civic authorities concerned to be able to use the licensed spaces for desired commercial purposes; the Authority shall facilitate where required and feasible.
- 11.4.12 The Licensee shall operate, manage, maintain and upkeep the entire licensed space with adequately trained and experienced staff and necessary equipment at its own cost.
- 11.4.13 Incidental expenses related to planning, installation, repair and O&M of the fixtures will be borne by the Licensee.
- 11.4.14 Licensee shall ensure strict adherence to Permit-To-Work (PTW) process and corresponding provisions in list of 'Event of Default' and safety guidelines of the Authority.
- 11.4.15 Right of Way to the station shall be provided to the Licensee as per pre-agreed schedule for O&M.
- 11.4.16 Non-intrusive O&M shall be permitted during non-peak hours, while Intrusive O&M shall be permitted during non-operational hours (12 am to 5 am) barring emergency situations; intrusive is interpreted as interfering with the core station operations.
- 11.4.17 The Authority shall provide security at stations which will oversee all station assets including fixtures at commercial spaces, however, the Authority shall not be liable for any theft or damage to the fixtures despite the security provided.
- 11.4.18 All fire-fighting equipment, pumps, common piping, etc. required to be installed outside the licensed spaces for firefighting arrangements shall be provided by the Authority up to a common point from where the Licensee shall make further arrangements within the licensed spaces.

- 11.4.19 Inside the licensed spaces, all firefighting arrangements, if any, including fire alarms and smoke detection systems, shall have to be installed by the Licensee and integrated in seamless manner with the Authority's system as applicable .
- 11.4.20 Such firefighting arrangements would conform to the National Building Code, relevant Building Byelaws / Indian Standards (IS) Codes, Fire Safety (Fire Prevention) Rules and any other instructions issued by the Authority in this regard.
- 11.4.21 Only after certification by the fire officer / authorized representative of the Authority, shall the Licensee be permitted to occupy and use the licensed spaces for commercial purposes.
- 11.4.22 The fire clearance before and after installation of the fire detection / fire-fighting system shall be obtained by the Licensee for the licensed spaces.
- 11.4.23 The Authority reserves the right to inspect the licensed spaces at any time during the License Period in connection with firefighting readiness.
- 11.4.24 The Authority may also issue directives in this regard which shall have to be adhered to and complied by the Licensee.
- 11.4.25 Any additional works as may be indicated on this account shall also be carried out by the Licensee at its own cost.
- 11.4.26 No claim for damages or compensation for inconvenience in this regard will be entertained by the Authority.
- 11.4.27 The Licensee shall at all times adhere to all provisions of the Metro Railway (Operation and Maintenance) Act, 2002 and amendments thereto and shall also comply with all notices and circulars issued by the Authority in this regard.
- 11.4.28 Under no circumstances shall the licensed space or facilities constructed or installed at the licensed space be mortgaged, charged or otherwise put under any lien (including negative lien), charge or encumbrance be created or agreed to be created in favour of any person including the lenders.
- 11.4.29 The Licensee's attention is drawn to the Contract Labour (Regulation and Abolition) Act, 1970 and the Maharashtra Contract Labour (Regulation and Abolition) Rules, 1971 and the Licensee shall comply with the provisions of the said Act and Rules framed there under.

11.5 Utilities & Services Provisions

- 11.5.1 The Authority shall provide provisions for electric and if feasible data connectivity for all units across Line 2A and 7; drainage and plumbing shall be provided only for blocks at Line 2A as indicated in the Typical Station Layout in this Policy. Licensee shall make arrangements to connect to the closest utility point provided.
- 11.5.2 The internal distribution of these utilities as required for the licensed spaces shall be installed by the Licensee at its own cost.
- 11.5.3 Air conditioning inside the glass façade setup by the Licensee in the licensed spaces shall be permitted subject to no conflict with metro utilities plan.
- 11.5.4 Side walls in the large block spaces at Andheri West station shall be permitted subject to no conflict with the metro utilities plan.
- 11.5.5 The Licensee will have to make its own arrangements storage and purification of water, including installation of meters at its own cost after taking all the necessary approvals.
- 11.5.6 A separate meter shall be installed at the cost of the Licensee for measuring electricity consumption.
- 11.5.7 Housekeeping and O&M of Licensee's respective units shall be done by the Licensee.
- 11.5.8 The charges for the utilities shall be payable by the Licensee on actuals as per the commercial rates applicable at the time.
- 11.5.9 Licensee's O&M staff is expected to monitor the health of the fixtures periodically and flag off any issues pertaining to seepages, etc. to the Authority which will then take necessary remedial action.
- 11.5.10 Garbage and debris should be disposed of as per pollution control guidelines given by the state government and local bodies.
- 11.5.11 The Licensee shall remove debris from the site of work within 24 hours from the date of written instructions to the Licensee to that effect, failing which the Authority will remove the same by engaging any other Entity or departmentally and the cost of the same shall be recovered from any money due to them; such decision shall not form the subject matter of any dispute.
- 11.5.12 The discharge of all wastes including drainage shall also be arranged by the Licensee at its own costs and in this connection, it shall follow all the directives as may be issued by the Authority.

11.6 Signage and Advertisements

- 11.6.1 The signage and advertisement should adhere to design guidelines specified in the Annexures.
- 11.6.2 The Licensee shall have the right to display signages of suitable size for displaying its logo / generic name. Signage should be used only for the business being run by the Licensee in the licensed premises.
- 11.6.3 The Licensee shall also need to obtain a written approval from the Authority before putting up any form of signage and the Authority reserves the right to refuse or to suggest an alternation to the same.
- 11.6.4 The size, shape, location, etc. of signage are subject to the design guidelines given in the Annexures.
- 11.6.5 The signage may be illuminated or non-illuminated at the Licensee's option, however it shall need to confirm to all governmental laws, regulations or ordinance relevant thereto.
- 11.6.6 The Licensee shall be required to use materials as per standards prevalent in global metro networks and in-line with the design guidelines given in the Annexures, for which he shall seek necessary approval from the Authority.
- 11.6.7 No third-party advertisement in any format shall be permitted at the licensed space. However, the Licensee shall be allowed to use interior and exterior of the licensed spaces for display of advertisement only related to the business / commodity being run / sold by the Licensee.
- 11.6.8 The Licensee shall need to obtain a written approval from the Authority before putting up any form of signage/ advertisement within / outside their units and the Authority reserves the right to refuse or to suggest alteration to the same. The signage/ advertisement shape and location etc. shall be in-line with design guidelines given in the Annexures.
- 11.6.9 Placement of signage / advertisement without permission of the Authority or placement in non-approved locations shall attract a penalty of Rs. 5,000/- per signage/ advertisement on the first occasion and Rs. 50,000/- per signage/ advertisement on the second occasion. In case of persistence of default, the Authority reserves the right to terminate the agreement and invoking Performance Security and advance License Fee paid in its favour.
- 11.6.10 The Authority shall not unreasonably interfere with the signage/ advertisement plan. If the Authority is not satisfied and raises any objections, the Licensee shall be required to appropriately amend/ modify its scheme within a reasonable timeframe and seek the Authority approval once again.

11.7 Other Provisions for the Licensed Spaces

- 11.7.1 The Licensee should attend the complaints pertaining to its installations within 3 days from the receipt of such letter issued by the Authority from time to time and shall comply with directions / instructions of the Authority in respect of the said works.
- 11.7.2 If at any time during the License Period, any Authority requests for concreting, fabrication, repair of structures, removal of fixtures, etc., the Licensee shall implement the same at its own expense upon such intimation from the Authority.
- 11.7.3 The Licensee shall immediately on receiving notice from the Authority rectify, at their own expense, the fault in the said work to the entire satisfaction of the Authority within three days from the date of receipt of such notice, failing which the Authority shall be at the liberty to proceed with the work required to be carried out at the risk and cost of the Licensee without any further notice to them as per License Agreement.
- 11.7.4 While the fixtures are being installed or removed or re-installed by the Licensee, it shall take all necessary safety precautions and if any damage is caused to, or is suffered by, a person or property of the Authority, or by any third party due to any cause whatsoever, the Licensee shall be solely responsible for compensation or damage to the Authority's property or the third party as the case may be and the Licensee shall indemnify and keep the Authority indemnified in respect of any claim made thereunder,
- 11.7.5 The Authority shall not be liable to pay any compensation in case the Licensee, their staff, agents or any other person meets with an accident or in case any injury is caused to or suffered by any one of them, or by any third-party, or to any property whatsoever while the work is undertaken by the Licensee. The Licensee shall keep the Authority indemnified in that respect. The Licensee shall also cover this through appropriate third-party insurance cover.
- 11.7.6 The Licensee shall not carry out any addition or alteration to the station structures whatsoever unless it is approved by the Authority.
- 11.7.7 The Licensee should deploy a Technical Supervisor to look after the licensed spaces at site and coordination with the officer in charge of the Authority.

- 11.7.8 If any temporary fixture on the said work is required to be shifted or removed urgently due to accidents, thefts, or on the direction of concerned Statutory Authorities, before the expiry of License Period for any other reason whatsoever, that fixture shall be removed by the Licensee forthwith within 48 hours of receipt of telephonic / written instructions by the Authority to that effect.
- 11.7.9 In case of failure to do so the Authority will arrange to have the same removed at the risk and cost of the Licensee. No compensation in that respect will be payable to the Licensee. The Licensee shall be, however, liable to pay the charges incurred for removing/ shifting fixtures. The Licensee shall collect the materials from the Authority's premises within 15 days from the date of receipt of intimation to them to that effect.
- 11.7.10 The Licensee shall ensure that all persons employed are well groomed and sanitized and behave in an orderly and disciplined manner and that the said employees are prohibited from carrying on any unlawful, unfair activities or demonstrations.
- 11.7.11 The Licensee shall submit the profile of personnel to whom it intends to employ/deploy for carrying out the installation work and operations. The personnel deployed should be without any adverse or criminal background. In this connection, Licensee shall be required to furnish declaration to the Authority with respect to all their personnel deployed. Further, in the Commercial Plan, the Licensee shall submit police verification report in respect of all its personnel to the Authority. All the Licensee's personnel shall be required to possess ID card issued by the Authority while working in the Authority's premises as per prevailing procedure. Access inside the stations in paid areas shall be through smart cards as per prevailing applicable charges, in addition to the valid ID cards.

12. Suspension & Termination

12.1 Force Majeure

- 12.1.1 Force Majeure here refers to an extraordinary event or circumstance beyond the control of the parties, such as a war, strike, riot, crime, pandemic, etc. which prevents one or both the parties from fulfilling their obligations under the License Agreement.
- 12.1.2 The failure of a Party to fulfil any of its obligations under the License Agreement shall not be considered to be a breach of, or default under this License, so far as such inability arises from an event of Force Majeure, provided that the Party affected by such an event has taken all reasonable precautions, due care and reasonable alternative measures, all with the objective of carrying out terms and conditions of this License.
- 12.1.3 A Party affected by an event of Force Majeure shall take all reasonable measures to remove such Party's inability to fulfil its obligations hereunder with a minimum of delay.
- 12.1.4 A Party affected by an event of Force Majeure shall notify the other Party of such event as soon as possible, and in any event, not later than 15 days following the occurrence of such event, providing evidence of the nature and causes of such event and shall similarly give notice of restoration of normal conditions as soon as they are restored.
- 12.1.5 The Parties shall take all reasonable measures to minimize the consequences of any event of Force Majeure.
- 12.1.6 The Authority shall have the right to partially / fully waive off the License Fee for the period of force majeure and / or extend the License Period to compensate for the period of reduced / NIL revenue after consultation with the Licensee.

12.2 Suspension of License

- 12.2.1 The Authority may suspend the License, by written notice to the Licensee, if the Licensee fails to perform its obligations under this License.
- 12.2.2 Such notice of suspension shall specify the nature of the failure and shall provide the Licensee a cure period to remedy such failure within a period not exceeding 30 days after receipt by the Licensee of such notice of suspension. The Licensee shall not be permitted to operate the commercial unit for the period of such suspension.
- 12.2.3 There shall be no adjustments to the License Fee paid by the Licensee in advance for the duration of such suspension.

12.3 Termination of License

- 12.3.1 The Authority shall, by not less than 30 days, give a written notice of termination to the Licensee after the occurrence of any of the following Events of Default -
- i. If the Licensee fails to remedy a failure in the performance of their obligations under the License, as specified in the notice of suspension, within 30 days of receipt of such notice or within such further period as the Authority may have subsequently approved in writing.
 - ii. If the Licensee becomes insolvent or bankrupt or enters into any agreements with their creditors for relief of debt or takes advantage of any law for the benefit of debtors or go into liquidation or receivership whether compulsory or voluntary.
 - iii. If the Licensee fails to comply with any final decision reached as a result of arbitration proceedings.
 - iv. If the Licensee submits to the Authority, any information/ document or representation which the Licensee knows to be false, and which has a material effect on the rights, obligations and interests of the Authority.
 - v. If, as a result of Force Majeure, the Licensee is unable to perform a material portion of the License for a period of not less than 60 days.
 - vi. If the Licensee, in the judgment of the Authority has engaged in corrupt or fraudulent practices in competing for or in executing the License.
- 12.3.2 If the Licensee terminates the License Agreement within the Lock-in Period, their furnished Performance Security shall be invoked by the Authority.
- 12.3.3 If the Licensee wants to terminate their License Agreement after the Lock-in Period, it shall give an advance notice prior to the termination to the Authority as prescribed in the Summary of Key Commercial Terms.
- 12.3.4 In case of abrupt termination without an advance notice as per the Summary of Terms prior to the termination by the Licensee, the Authority shall invoke their furnished Performance Security.
- 12.3.5 Upon termination or expiry of this License, all rights and obligations of the Parties hereunder shall cease, except -
- a. Such rights and obligations as may have accrued on the date of termination or expiration
 - b. The obligation of confidentiality
 - c. Any right which a Party may continue to have under applicable law

12.4 Dispute Resolution

- 12.4.1 Except where otherwise specified in the License Agreement and subject to the powers delegated to him / her by the Authority in force, the decision of Director (Finance) shall be final, conclusive and binding on all Parties to the License for all questions relating to the meaning and interpretation of the License conditions or regarding any other question, claim, right, matter or things whatsoever arising out of or relating to the License.
- 12.4.2 If the Licensee is not satisfied with the order passed by Director (Finance) as aforesaid, the Licensee may within 30 days of receipt by him / her of any such order, appeal against it to the Managing Director (MD) of the Authority who, if convinced that prima facie the Licensee's claim rejected by Director (Finance) is not frivolous and that there is some substance in the claim of the Licensee and would merit a detailed examination through a suitable committee appointed for the purpose by the MD if necessary and in that case, decision taken by the committee shall be finalized by the Authority and same shall be binding to the Licensee.
- 12.4.3 If the Licensee is still not satisfied with the resolution, then legal action may be initiated where courts of Mumbai shall have the exclusive jurisdiction.

13. Other Terms

13.1 Conflict of Interest

- 13.1.1 The Applicant shall not have a Conflict of Interest that affects the Allotment Process. Any Applicant found to have such a Conflict of Interest shall be disqualified.
- 13.1.2 In the event of disqualification, the Authority shall appropriate the Bid Security (EMD), if any, as damages payable to the Authority for, inter alia, the time, cost and effort of the Authority, including consideration of such Applicant's Application, without prejudice to any other right or remedy that may be available to the Authority under this Policy or otherwise.
- 13.1.3 Without limiting the generality of the above, an Applicant shall be deemed to have a Conflict of Interest affecting the Allotment Process, if:
- i. A constituent of Applicant is also a constituent of another Applicant.
 - ii. Applicant, its Member or any Associate thereof receives or has received any direct or indirect subsidy, grant, concessional loan or subordinated debt from any other Applicant, its Member or Associate, or has provided any such subsidy, grant, concessional loan or subordinated debt to any other Applicant, its Member or any Associate thereof.
 - iii. Applicant has the same legal representative for purposes of this Application as any other Applicant.
 - iv. Such Applicant, or any Associate thereof, has a relationship with another Applicant, or any Associate thereof, directly or through common third party/ parties, that puts either or both of them in a position to have access to each other's information about, or to influence their Applications.
 - v. Such Applicant or any Associate thereof has participated as a consultant/contractor to the Authority in the preparation of any documents regarding this Policy.

----- INTENTIONALLY LEFT BLANK -----

15.2 Corrupt & Fraudulent Practices

- 13.2.1 The Applicant and their personnel shall observe the highest standard of ethics during the tender process and must not indulge in any corrupt or fraudulent practice defined here under:
- i. 'Corrupt practice' is the offering, giving, receiving or soliciting, directly or indirectly, of anything of value to influence improperly the actions of another party.
 - ii. 'Fraudulent practice' is any act or omission, including misrepresentation, that knowingly or recklessly misleads, or attempts to mislead a party to obtain financial or other benefit or to avoid an obligation.
 - iii. 'Collusive practices' is an arrangement between two or more parties designed to achieve an improper purpose, including to influence improperly the actions of another party.
 - iv. 'Coercive practices' is impairing or harming or threatening to impair or harm, directly or indirectly, any party or the property of the party to influence improperly the actions of a party.

13.3 Confidentiality

- 13.3.1 From the time the Applications are opened to the time the License is awarded, the Applicant should not contact the Authority on any matter related to its Application.
- 13.3.2 Information relating to the evaluation of Applications and award recommendations shall not be disclosed to the Applicants who submitted the Applications or to any other party not officially concerned with the process, until the License is awarded.
- 13.3.3 Any attempt by Applicants or anyone on behalf of the Applicant to influence the Authority improperly in the evaluation of the Applications or License award decisions may result in the rejection of its Application.
- 13.3.4 Notwithstanding the above provisions, from the time of the Applications' opening to the time of License award, if an Applicant wishes to contact the Authority on any matter related to the selection process, it should do so only in writing.

Annexure 1: Application Letter

< to be submitted on Applicant's letterhead >

To,

Manager (Commercial)

Maha Mumbai Metro Operation Corporation Limited (MMMOCL)
2nd Floor, NAMTTRI Building, Adjoining New MMRDA Building,
Bandra Kurla Complex, Bandra East, Mumbai 400051

Sub: Application towards Policy for appointment for licensing of spaces at Mumbai Metro line 2A & 7 stations for retail & other commercial uses

Sir,

Being duly authorized to represent and act for and on behalf of
(the 'Applicant'), the undersigned hereby submits our Application for Licensing of spaces at Mumbai Metro line 2A & 7 stations for retail & other commercial uses, according to the terms and conditions of this Policy.

Our application of Retail Kiosks and/or Blocks along with respective License Fee is enclosed herewith.

MMMOCL's representatives may contact the following for further information:

Name & Designation:

Phone & Email:

This Application is made with full understanding that MMOCL reserves the right to reject or accept any / all Applications and / or cancel the Policy, for which MMOCL shall not be liable nor under any obligation to inform the Applicant of the same.

I, the undersigned, declare the statements made and the information provided in our Application Letter are complete and accurate. I confirm that I have read, understood and accepted the terms and conditions of this Policy. I undertake that I am not debarred by any of the central or state government bodies as listed in this Policy in terms of participation in any public tender or agreement.

Sincerely,

Name, Designation & Sign of authorized signatory:

Name & Seal of Applicant:

Date & Place:

Enclosures:

SN	Document Checklist	Enclosed with the Application Letter (tick)
1	Application letter	
3	Statutory Auditor Certificate	
4	Power of Attorney or Board Resolution in favour of authorised signatory	
5	Indemnity Bond	
6	Solvency Certificate	
7	Company Incorporation Certificate PAN, TAN, GST registration documents	
8	Company Brochure	
10	Audited financial statements for preceding three financial years	
11	Self-attested Policy document with full signature on first and last page and initials on all other pages	
12	Duly filled Excel Template mentioning the Units applied for and the License Fee	

Sincerely,

Name, Designation & Sign of authorized signatory:

Name & Seal of Applicant:

Date & Place

Note: < not to be printed on the Application letter >

- i. Audited financial statements shall be submitted by the Applicant for preceding three financial years.
- ii. Audited financial statements and Policy documents are required to be self-attested on the first and last page of the documents either through ink or digital signature, and all other pages have to be initialed by the Authorized Signatory
- iii. The Application Letter along with relevant enclosures shall be sent to the following address: c/o Manager Commercial, Maha Mumbai Metro Operation Corporation Limited, 2nd Floor, NaMTTRI Building, Plot No. R-13, E-Block, Bandra Kurla Complex, Bandra East, Mumbai 400051, Email: mgco@mmmoocl.co.in

Annexure 2: Power of Attorney Format

< to be submitted on non-judicial stamp paper of Rs 500 duly notarized >

Know all men by these presents, we, <name of firm and address of the registered office> do hereby constitute, nominate, appoint and authorise Mr. / Ms. <name of person> who is presently employed with us and holding the position of <designation> as our true and lawful attorney (hereinafter referred to as the “Authorised Representative”) to do in our name and on our behalf, all such acts, deeds and things as are necessary or required in connection with or incidental to submission of our Application for the “Licensing of Spaces at Mumbai Metro Line 2A and 7 stations for Retail and Commercial Uses” including but not limited to signing and submission of all applications, proposals and other documents and writings, participating in pre-bid and other conferences, if any, and providing information/ responses to the Authority, representing us in all matters before the Authority, signing and execution of all contracts and undertakings consequent to acceptance of our application and generally dealing with the Authority in all matters in connection with or relating to or arising out of our Application for the said Tender and/or upon award thereof to us till the entering into of the Agreement with the Authority.

AND we do hereby agree to ratify and confirm all acts, deeds and things lawfully done or caused to be done by our said Authorised Representative pursuant to and in exercise of the powers conferred by this Power of Attorney and that all acts, deeds and things done by our said Authorised Representative in exercise of the powers hereby conferred shall and shall always be deemed to have been done by us.

IN WITNESS WHERE OF WE, THE ABOVE-NAMED PRINCIPAL HAVE EXECUTED THIS POWER OF ATTORNEY ON THIS <date> DAY OF <month>, 20**.

For,
(Signature, name, designation and address)

Witnesses:

- 1.
- 2.

Notarised
Accepted
(Signature, name, designation and address of the Attorney)

Notes:

- 1) The mode of execution of the Power of Attorney should be in accordance with the procedure, if any, laid down by the applicable law and the charter documents of the executants (s) and when it is so required the same should be under common seal affixed in accordance with the required procedure. The Power of Attorney should be executed on a non-judicial stamp paper of Rs. 500 and duly notarised by a notary public.
- 2) Wherever required, the Applicant should submit for verification the extract of the charter documents and other documents such as a resolution/power of attorney in favour of the person executing this Power of Attorney for the delegation of power hereunder on behalf of the Applicant.
- 3) For a Power of Attorney executed and issued overseas, the document will also have to be legalised by the Indian Embassy and notarised in the jurisdiction where the Power of Attorney is being issued. However, Applicants from countries that have signed the Hague Legislation Convention 1961 need not get their Power of Attorney legalised by the Indian Embassy if it carries a conforming Apostille certificate.
- 4) The Applicant shall submit a Power of Attorney or Company Board Resolution in favour of the authorized signatory.

Annexure 3: Statutory Auditor Certificate

< on letter head of Statutory Auditor / reputed Chartered Accountant >

TO WHOMSOEVER IT MAY CONCERN

We, <name of the CA firm>, are statutory auditors of <name of firm>. This is to certify that the Turnover and Net worth of <name of firm> is as follows –

Financial Year	Figures in Rs Cr
Year 1 Gross Revenue	
Year 2 Gross Revenue	
Year 3 Gross Revenue (preceding FY)	
Average of the above 3 years	
Net worth as of (preceding FY)	

For,
Chartered Accountants
Membership Number
UDIN:

Authorized Signatory:

Date:

Note:

Figures in Rs Cr to be shown with two decimal points

Gross Revenue for preceding three financial years from the date of submission of the Application

Net worth as of March 31st of the preceding Financial Year

Annexure 4: Indemnity Bond

< to be submitted on non-judicial stamp paper of Rs 500 duly notarized >

This Indemnity is made and executed at on this [*] day of [*] 2023 by M/s [name of firm] represented by [name of representative], its [designation], having its administrative office at [*] hereinafter referred to as the INDEMNIFIER – LICENSEE

IN FAVOUR OF Maha Mumbai Metro Operation Corporation Ltd (MMMOCL) hereinafter called INDEMNIFIED – LICENSOR,

The terms “INDEMNIFIER-LICENSEE” and the “INDEMNIFIED – MMOCL” unless repugnant to the context shall mean and include legal representatives, successors, executors and administrators.

I hereby irrevocably agree to indemnify and protect MMOCL from and against all claims and proceedings, actions, suits, claims, damages, losses, expenses and demands of every nature and description, by reasons of any act or omission by myself or by my representative or by my employees in the execution of the License Agreement. This indemnification obligation includes but is not limited to claims, damages, losses, damage-proceedings, charges and expenses which are attributable to -

- a. Sickness or disease or death or injury to any person, and
- b. Loss of, or damage to, or destruction of any property including consequential loss or use, and
- c. Loss or damage or costs arising from the carriage of materials of any subcontractor or any third-party

All sums payable by way of compensation under these conditions shall be considered reasonable compensation payable to MMOCL without reference to actual loss or damage sustained and whether or not any damage shall have been sustained. The decision of MMOCL as to compensation claimed shall be final and binding.

IN WITNESS whereof, the Licensee have put their signatures in the presence of the witnesses.

(Name, signature, seal, date and address of Licensee)

Two Witnesses' Signature Name and Address

Annexure 5: Solvency Certificate

<On the letterhead of Bank only>

<To be dated within 3 months of contract execution>

This is to certify that Shri. / M/s. has / have been maintaining a savings / current account with us since last years. From his / her dealing with us we have found him as follows:

To the best of our knowledge and information he/she is / they are solvent to the extent of Rs. (Rupees Only).

This certificate is issued at the specific request of the customer M/s

Authorised Signatory,

Date:

Seal

Annexure 6: Inventory of commercial spaces available

- Refer attached excel file for inventory list
- Also refer attached layouts of the metro stations
- Applicant is required to tally the Unit Number given in the excel sheet with the unit number given in the layout to understand the location of the units available.
- Applicant may apply for units at or above the Base Price mentioned in the inventory list.

Annexure 6: Inventory of commercial spaces available

SN	Line	Station	Area	Format	Layout Unit No.	Usable Area (sqft)	Base Rate (In Rs.)
1	L2A	Andheri West	Unpaid North	Block Small	UN-BS-1A	575	2,30,575
2	L2A	Andheri West	Unpaid North	Block Small	UN-BS-1B	640	2,56,640
3	L2A	Andheri West	Unpaid North	Block Small	UN-BS-2	2,474	11,15,774
4	L2A	Andheri West	Unpaid South	Block Small	US-BS-1A	2,501	10,02,901
5	L2A	Andheri West	Unpaid South	Block Small	US-BS-1B	1,215	4,87,215
6	L2A	Andheri West	Unpaid South	Block Small	US-BS-1C	989	4,46,039
7	L2A	Andheri West	Unpaid South	Block Small	US-BS-2	1,677	6,72,477
8	L2A	Andheri West	Unpaid South	Block Small	US-BS-3	3,482	10,48,082
9	L2A	Andheri West	Paid Middle	Kiosk Large	PM-KL-1A	100	70,100
10	L2A	Andheri West	Unpaid South	Block Small	US-BS-1	3,226	9,71,026
11	L2A	Andheri West	Paid Middle	Kiosk Medium	PM-KM-1A	50	28,750
12	L2A	Andheri West	Paid Middle	Kiosk Medium	PM-KM-1B	50	28,750
13	L2A	Andheri West	Paid Middle	Kiosk Medium	PM-KM-1C	50	28,750
14	L2A	Andheri West	Paid Middle	Kiosk Medium	PM-KM-1D	50	28,750
15	L2A	Lower Oshiwara	Unpaid North	Kiosk Small	UN-KS-1B	26	22,100
16	L2A	Lower Oshiwara	Paid Middle	Kiosk Large	PM-KL-1B	100	70,100
17	L2A	Lower Oshiwara	Paid Middle	Kiosk Medium	PM-KM-1A	50	45,000
18	L2A	Lower Oshiwara	Paid Middle	Kiosk Medium	PM-KM-1B	50	17,550
19	L2A	Lower Oshiwara	Paid Middle	Kiosk Medium	PM-KM-1C	50	17,550
20	L2A	Lower Oshiwara	Paid Middle	Kiosk Large	PM-KL-2A	100	70,100
21	L2A	Lower Oshiwara	Paid Middle	Kiosk Large	PM-KL-2B	100	70,100
22	L2A	Lower Oshiwara	Unpaid South	Block Small	US-BS-1	2,307	5,79,057
23	L2A	Oshiwara	Unpaid North	Block Small	UN-BS-1	1,903	4,96,683
24	L2A	Oshiwara	Unpaid North	Kiosk Small	UN-KS-1B	26	11,700
25	L2A	Oshiwara	Paid Middle	Kiosk Large	PM-KL-1A	100	45,100
26	L2A	Oshiwara	Paid Middle	Kiosk Large	PM-KL-1B	100	45,100
27	L2A	Oshiwara	Paid Middle	Kiosk Medium	PM-KM-1A	50	30,000
28	L2A	Oshiwara	Paid Middle	Kiosk Medium	PM-KM-1B	50	15,050

Applicant may apply for units at or above the Base Price mentioned in the inventory list.

Annexure 6: Inventory of commercial spaces available

SN	Line	Station	Area	Format	Layout Unit No.	Usable Area (sqft)	Base Rate (In Rs.)
29	L2A	Oshiwara	Paid Middle	Kiosk Medium	PM-KM-1C	50	15,050
30	L2A	Oshiwara	Paid Middle	Kiosk Medium	PM-KM-1D	50	15,050
31	L2A	Oshiwara	Paid Middle	Kiosk Large	PM-KL-2A	100	45,100
32	L2A	Oshiwara	Paid Middle	Kiosk Large	PM-KL-2B	100	45,100
33	L2A	Oshiwara	Unpaid South	Kiosk Small	US-KS-1A	26	13,000
34	L2A	Goregaon West	Unpaid North	Kiosk Large	UN-KL-1	65	22,815
35	L2A	Goregaon West	Unpaid North	Kiosk Small	UN-KS-1B	26	9,100
36	L2A	Goregaon West	Paid Middle	Kiosk Large	PM-KL-1A	100	45,100
37	L2A	Goregaon West	Paid Middle	Kiosk Large	PM-KL-1B	100	45,100
38	L2A	Goregaon West	Paid Middle	Kiosk Medium	PM-KM-1A	50	20,000
39	L2A	Goregaon West	Paid Middle	Kiosk Medium	PM-KM-1B	50	15,050
40	L2A	Goregaon West	Paid Middle	Kiosk Medium	PM-KM-1C	50	15,050
41	L2A	Goregaon West	Paid Middle	Kiosk Medium	PM-KM-1D	50	15,050
42	L2A	Goregaon West	Paid Middle	Kiosk Large	PM-KL-2B	100	45,100
43	L2A	Goregaon West	Unpaid South	Block Small	US-BS-1	1,996	7,20,556
44	L2A	Bangur Nagar	Unpaid North	Kiosk Large	UN-KL-1	65	22,815
45	L2A	Bangur Nagar	Unpaid North	Kiosk Small	UN-KS-2	26	6,526
46	L2A	Bangur Nagar	Paid Middle	Kiosk Large	PM-KL-1A	100	45,100
47	L2A	Bangur Nagar	Paid Middle	Kiosk Large	PM-KL-1B	100	45,100
48	L2A	Bangur Nagar	Paid Middle	Kiosk Medium	PM-KM-1A	50	15,050
49	L2A	Bangur Nagar	Paid Middle	Kiosk Medium	PM-KM-1B	50	15,050
50	L2A	Bangur Nagar	Paid Middle	Kiosk Medium	PM-KM-1C	50	15,050
51	L2A	Bangur Nagar	Paid Middle	Kiosk Medium	PM-KM-1D	50	15,050
52	L2A	Bangur Nagar	Paid Middle	Kiosk Large	PM-KL-2A	100	45,100
53	L2A	Bangur Nagar	Paid Middle	Kiosk Large	PM-KL-2B	100	45,100
54	L2A	Bangur Nagar	Unpaid South	Block Small	US-BS-1	1,985	7,16,585
55	L2A	Bangur Nagar	Unpaid South	Kiosk Small	US-KS-1	26	6,526
56	L2A	Lower Malad	Unpaid North	Kiosk Large	UN-KL-1	65	35,815

Applicant may apply for units at or above the Base Price mentioned in the inventory list.

Annexure 6: Inventory of commercial spaces available

SN	Line	Station	Area	Format	Layout Unit No.	Usable Area (sqft)	Base Rate (In Rs.)
57	L2A	Lower Malad	Paid Middle	Kiosk Large	PM-KL-1A	100	70,100
58	L2A	Lower Malad	Paid Middle	Kiosk Large	PM-KL-1B	100	70,100
59	L2A	Lower Malad	Paid Middle	Kiosk Medium	PM-KM-1A	50	17,550
60	L2A	Lower Malad	Paid Middle	Kiosk Medium	PM-KM-1D	50	45,000
61	L2A	Lower Malad	Paid Middle	Kiosk Large	PM-KL-2A	100	70,100
62	L2A	Lower Malad	Paid Middle	Kiosk Large	PM-KL-2B	100	70,100
63	L2A	Lower Malad	Unpaid South	Block Small	US-BS-1	2,182	8,18,250
64	L2A	Malad West	Paid Middle	Kiosk Large	PM-KL-1A	100	55,000
65	L2A	Malad West	Paid Middle	Kiosk Medium	PM-KM-1A	50	54,000
66	L2A	Malad West	Paid Middle	Kiosk Medium	PM-KM-1B	50	15,050
67	L2A	Malad West	Paid Middle	Kiosk Large	PM-KL-2A	100	45,100
68	L2A	Malad West	Paid Middle	Kiosk Large	PM-KL-2B	100	45,100
69	L2A	Malad West	Unpaid South	Block Small	US-BS-1	1,947	5,08,167
70	L2A	Malad West	Paid Middle	Kiosk Large	PM-KL-1B	100	50,000
71	L2A	Valnai	Unpaid North	Kiosk Large	UN-KL-1	65	38,000
72	L2A	Valnai	Paid Middle	Kiosk Large	PM-KL-1A	100	45,100
73	L2A	Valnai	Paid Middle	Kiosk Large	PM-KL-1B	100	45,100
74	L2A	Valnai	Paid Middle	Kiosk Medium	PM-KM-1A	50	15,050
75	L2A	Valnai	Paid Middle	Kiosk Medium	PM-KM-1B	50	15,050
76	L2A	Valnai	Paid Middle	Kiosk Medium	PM-KM-1C	50	15,050
77	L2A	Valnai	Paid Middle	Kiosk Medium	PM-KM-1D	50	15,050
78	L2A	Valnai	Paid Middle	Kiosk Large	PM-KL-2A	100	45,100
79	L2A	Valnai	Paid Middle	Kiosk Large	PM-KL-2B	100	45,100
80	L2A	Valnai	Unpaid South	Block Small	US-BS-1	2,188	5,70,024
81	L2A	Dahanukarwadi	Unpaid North	Kiosk Small	UN-KS-1	26	14,300
82	L2A	Dahanukarwadi	Paid Middle	Kiosk Large	PM-KL-1A	100	45,100
83	L2A	Dahanukarwadi	Paid Middle	Kiosk Large	PM-KL-1B	100	45,100
84	L2A	Dahanukarwadi	Paid Middle	Kiosk Large	PM-KL-2B	100	45,100

Applicant may apply for units at or above the Base Price mentioned in the inventory list.

Annexure 6: Inventory of commercial spaces available

SN	Line	Station	Area	Format	Layout Unit No.	Usable Area (sqft)	Base Rate (In Rs.)
85	L2A	Dahanukarwadi	Unpaid South	Block Small	US-BS-1	2,014	5,25,654
86	L2A	Kandivali West	Unpaid North	Kiosk Small	UN-KS-1A	26	14,300
87	L2A	Kandivali West	Paid Middle	Kiosk Large	PM-KL-1A	100	70,100
88	L2A	Kandivali West	Paid Middle	Kiosk Large	PM-KL-1B	100	70,100
89	L2A	Kandivali West	Paid Middle	Kiosk Medium	PM-KM-1A	50	40,000
90	L2A	Kandivali West	Paid Middle	Kiosk Medium	PM-KM-1B	50	17,550
91	L2A	Kandivali West	Paid Middle	Kiosk Medium	PM-KM-1C	50	17,550
92	L2A	Kandivali West	Paid Middle	Kiosk Large	PM-KL-2A	100	70,100
93	L2A	Kandivali West	Paid Middle	Kiosk Large	PM-KL-2B	100	70,100
94	L2A	Kandivali West	Unpaid South	Block Small	US-BS-1A	703	2,63,625
95	L2A	Kandivali West	Unpaid South	Block Small	US-BS-1B	459	1,72,125
96	L2A	Kandivali West	Unpaid South	Kiosk Small	US-KS-1A	26	13,000
97	L2A	Shimpoli	Unpaid North	Kiosk Large	UN-KL-1	65	38,000
98	L2A	Shimpoli	Paid Middle	Kiosk Large	PM-KL-1A	100	70,100
99	L2A	Shimpoli	Paid Middle	Kiosk Large	PM-KL-1B	100	70,100
100	L2A	Shimpoli	Paid Middle	Kiosk Medium	PM-KM-1A	50	17,550
101	L2A	Shimpoli	Paid Middle	Kiosk Medium	PM-KM-1B	50	17,550
102	L2A	Shimpoli	Paid Middle	Kiosk Medium	PM-KM-1C	50	17,550
103	L2A	Shimpoli	Paid Middle	Kiosk Medium	PM-KM-1D	50	17,550
104	L2A	Shimpoli	Paid Middle	Kiosk Large	PM-KL-2A	100	70,100
105	L2A	Shimpoli	Paid Middle	Kiosk Large	PM-KL-2B	100	70,100
106	L2A	Shimpoli	Unpaid South	Block Small	US-BS-1	1,846	6,92,250
107	L2A	Borivali West	Paid Middle	Kiosk Large	PM-KL-1B	100	70,100
108	L2A	Borivali West	Paid Middle	Kiosk Medium	PM-KM-1B	50	17,550
109	L2A	Borivali West	Paid Middle	Kiosk Medium	PM-KM-1C	50	17,550
110	L2A	Borivali West	Paid Middle	Kiosk Medium	PM-KM-1D	50	45,000
111	L2A	Borivali West	Paid Middle	Kiosk Large	PM-KL-2A	100	70,100
112	L2A	Borivali West	Paid Middle	Kiosk Large	PM-KL-2B	100	70,100

Applicant may apply for units at or above the Base Price mentioned in the inventory list.

Annexure 6: Inventory of commercial spaces available

SN	Line	Station	Area	Format	Layout Unit No.	Usable Area (sqft)	Base Rate (In Rs.)
113	L2A	Borivali West	Unpaid South	Block Small	US-BS-1	2,345	8,79,375
114	L2A	Eksar	Unpaid North	Kiosk Large	UN-KL-1	65	32,500
115	L2A	Eksar	Unpaid North	Kiosk Small	UN-KS-1B	26	13,000
116	L2A	Eksar	Paid Middle	Kiosk Large	PM-KL-1A	100	45,100
117	L2A	Eksar	Paid Middle	Kiosk Large	PM-KL-1B	100	45,100
118	L2A	Eksar	Paid Middle	Kiosk Large	PM-KL-2A	100	45,100
119	L2A	Eksar	Paid Middle	Kiosk Large	PM-KL-2B	100	45,100
120	L2A	Eksar	Unpaid South	Block Small	US-BS-1	2,179	5,68,719
121	L2A	Eksar	Unpaid South	Kiosk Small	US-KS-1B	26	13,000
122	L2A	Mandapeshwar	Paid Middle	Kiosk Large	PM-KL-1A	100	45,100
123	L2A	Mandapeshwar	Paid Middle	Kiosk Large	PM-KL-1B	100	45,100
124	L2A	Mandapeshwar	Paid Middle	Kiosk Medium	PM-KM-1A	50	15,050
125	L2A	Mandapeshwar	Paid Middle	Kiosk Medium	PM-KM-1B	50	15,050
126	L2A	Mandapeshwar	Paid Middle	Kiosk Medium	PM-KM-1C	50	15,050
127	L2A	Mandapeshwar	Paid Middle	Kiosk Medium	PM-KM-1D	50	15,050
128	L2A	Mandapeshwar	Paid Middle	Kiosk Large	PM-KL-2A	100	45,100
129	L2A	Mandapeshwar	Paid Middle	Kiosk Large	PM-KL-2B	100	45,100
130	L2A	Mandapeshwar	Unpaid South	Block Small	US-BS-1	2,399	6,26,139
131	L2A	Kandarpada	Paid Middle	Kiosk Large	PM-KL-1A	100	45,100
132	L2A	Kandarpada	Paid Middle	Kiosk Large	PM-KL-1B	100	45,100
133	L2A	Kandarpada	Paid Middle	Kiosk Medium	PM-KM-1B	50	15,050
134	L2A	Kandarpada	Paid Middle	Kiosk Medium	PM-KM-1C	50	15,050
135	L2A	Kandarpada	Paid Middle	Kiosk Medium	PM-KM-1D	50	40,000
136	L2A	Kandarpada	Paid Middle	Kiosk Large	PM-KL-2A	100	45,100
137	L2A	Kandarpada	Paid Middle	Kiosk Large	PM-KL-2B	100	55,000
138	L2A	Kandarpada	Unpaid South	Block Small	US-BS-1	2,066	5,39,226
139	L2A	Kandarpada	Unpaid South	Kiosk Small	US-KS-1B	26	23,400
140	L2A	Anand Nagar	Unpaid North	Block Small	UN-BS-1	2,427	6,33,447

Applicant may apply for units at or above the Base Price mentioned in the inventory list.

Annexure 6: Inventory of commercial spaces available

SN	Line	Station	Area	Format	Layout Unit No.	Usable Area (sqft)	Base Rate (In Rs.)
141	L2A	Anand Nagar	Paid Middle	Kiosk Large	PM-KL-1A	100	45,100
142	L2A	Anand Nagar	Paid Middle	Kiosk Large	PM-KL-1B	100	45,100
143	L2A	Anand Nagar	Paid Middle	Kiosk Medium	PM-KM-1A	50	15,050
144	L2A	Anand Nagar	Paid Middle	Kiosk Medium	PM-KM-1B	50	15,050
145	L2A	Anand Nagar	Paid Middle	Kiosk Medium	PM-KM-1C	50	15,050
146	L2A	Anand Nagar	Paid Middle	Kiosk Medium	PM-KM-1D	50	15,050
147	L2A	Anand Nagar	Paid Middle	Kiosk Large	PM-KL-2A	100	45,100
148	L2A	Anand Nagar	Paid Middle	Kiosk Large	PM-KL-2B	100	45,100
149	L2A	Anand Nagar	Unpaid South	Kiosk Small	US-KS-1A	26	6,526
150	L2A	Dahisar East	Unpaid North	Kiosk Large	UN-KL-1B	65	52,000
151	L2A	Dahisar East	Unpaid North	Kiosk Large	UN-KL-2A	65	52,000
152	L2A	Dahisar East	Unpaid North	Kiosk Large	UN-KL-2B	65	52,000
153	L2A	Dahisar East	Unpaid North	Kiosk Large	UN-KL-3A	65	55,350
154	L2A	Dahisar East	Unpaid North	Kiosk Large	UN-KL-3B	65	52,000
155	L2A	Dahisar East	Paid Middle	Kiosk Large	PM-KL-1A	100	45,100
156	L2A	Dahisar East	Paid Middle	Kiosk Medium	PM-KM-1D	50	50,000
157	L2A	Dahisar East	Paid Middle	Kiosk Large	PM-KL-2A	100	63,000
158	L2A	Dahisar East	Paid Middle	Kiosk Large	PM-KL-2B	100	45,100
159	L2A	Dahisar East	Unpaid South	Kiosk Large	US-KL-1	65	58,500
160	L7	Ovaripada	Unpaid North	Kiosk Large	UN-KL-1A	65	55,250
161	L7	Ovaripada	Unpaid North	Kiosk Small	UN-KS-1A	26	23,400
162	L7	Ovaripada	Paid Middle	Kiosk Large	PM-KL-1A	100	45,100
163	L7	Ovaripada	Paid Middle	Kiosk Large	PM-KL-1B	100	45,100
164	L7	Ovaripada	Paid Middle	Kiosk Large	PM-KL-2A	100	35,100
165	L7	Ovaripada	Paid Middle	Kiosk Large	PM-KL-2B	100	40,000
166	L7	Ovaripada	Paid Middle	Kiosk Large	PM-KL-3A	100	35,100
167	L7	Ovaripada	Paid Middle	Kiosk Large	PM-KL-3B	100	35,100
168	L7	Ovaripada	Paid Middle	Kiosk Medium	PM-KM-1A	50	35,000

Applicant may apply for units at or above the Base Price mentioned in the inventory list.

Annexure 6: Inventory of commercial spaces available

SN	Line	Station	Area	Format	Layout Unit No.	Usable Area (sqft)	Base Rate (In Rs.)
169	L7	Ovaripada	Paid Middle	Kiosk Medium	PM-KM-1B	50	15,050
170	L7	Ovaripada	Paid Middle	Kiosk Medium	PM-KM-1C	50	15,050
171	L7	Ovaripada	Paid Middle	Kiosk Medium	PM-KM-1D	50	15,050
172	L7	Ovaripada	Paid Middle	Kiosk Large	PM-KL-4A	100	45,100
173	L7	Ovaripada	Paid Middle	Kiosk Large	PM-KL-4B	100	45,100
174	L7	Ovaripada	Unpaid South	Kiosk Large	US-KL-1	65	39,000
175	L7	Ovaripada	Unpaid South	Kiosk Large	US-KL-2	65	32,000
176	L7	Ovaripada	Unpaid South	Kiosk Small	US-KS-1A	26	23,400
177	L7	Rashtriya Udyaan	Unpaid North	Kiosk Large	UN-KL-1	65	32,500
178	L7	Rashtriya Udyaan	Unpaid North	Kiosk Small	UN-KS-1A	26	13,000
179	L7	Rashtriya Udyaan	Paid Middle	Kiosk Large	PM-KL-1A	100	45,100
180	L7	Rashtriya Udyaan	Paid Middle	Kiosk Large	PM-KL-1B	100	45,100
181	L7	Rashtriya Udyaan	Paid Middle	Kiosk Large	PM-KL-2A	100	35,100
182	L7	Rashtriya Udyaan	Paid Middle	Kiosk Large	PM-KL-2B	100	35,100
183	L7	Rashtriya Udyaan	Paid Middle	Kiosk Large	PM-KL-3A	100	35,100
184	L7	Rashtriya Udyaan	Paid Middle	Kiosk Large	PM-KL-3B	100	35,100
185	L7	Rashtriya Udyaan	Paid Middle	Kiosk Medium	PM-KM-1A	50	15,050
186	L7	Rashtriya Udyaan	Paid Middle	Kiosk Medium	PM-KM-1B	50	15,050
187	L7	Rashtriya Udyaan	Paid Middle	Kiosk Medium	PM-KM-1D	50	15,050
188	L7	Rashtriya Udyaan	Paid Middle	Kiosk Large	PM-KL-4A	100	45,100
189	L7	Rashtriya Udyaan	Paid Middle	Kiosk Large	PM-KL-4B	100	45,100
190	L7	Rashtriya Udyaan	Unpaid South	Kiosk Large	US-KL-1A	65	29,250
191	L7	Rashtriya Udyaan	Unpaid South	Kiosk Large	US-KL-1B	65	29,250
192	L7	Rashtriya Udyaan	Unpaid South	Kiosk Small	US-KS-1A	26	29,250
193	L7	Devipada	Unpaid North	Kiosk Large	UN-KL-1A	81	28,431
194	L7	Devipada	Unpaid North	Kiosk Large	UN-KL-1B	81	28,431
195	L7	Devipada	Unpaid North	Kiosk Large	UN-KL-2A	81	28,431
196	L7	Devipada	Unpaid North	Kiosk Large	UN-KL-3	182	63,882

Applicant may apply for units at or above the Base Price mentioned in the inventory list.

Annexure 6: Inventory of commercial spaces available

SN	Line	Station	Area	Format	Layout Unit No.	Usable Area (sqft)	Base Rate (In Rs.)
197	L7	Devipada	Unpaid North	Kiosk Large	UN-KL-2B	81	38,310
198	L7	Devipada	Unpaid North	Kiosk Small	UN-KS-1	26	13,000
199	L7	Devipada	Paid Middle	Kiosk Large	PM-KL-1A	100	45,100
200	L7	Devipada	Paid Middle	Kiosk Large	PM-KL-1B	100	45,100
201	L7	Devipada	Paid Middle	Kiosk Large	PM-KL-2A	100	35,100
202	L7	Devipada	Paid Middle	Kiosk Large	PM-KL-2B	100	35,100
203	L7	Devipada	Paid Middle	Kiosk Large	PM-KL-3A	100	35,100
204	L7	Devipada	Paid Middle	Kiosk Large	PM-KL-3B	100	35,100
205	L7	Devipada	Paid Middle	Kiosk Medium	PM-KM-1A	50	15,050
206	L7	Devipada	Paid Middle	Kiosk Medium	PM-KM-1B	50	15,050
207	L7	Devipada	Paid Middle	Kiosk Medium	PM-KM-1C	50	15,050
208	L7	Devipada	Paid Middle	Kiosk Medium	PM-KM-1D	50	16,000
209	L7	Devipada	Paid Middle	Kiosk Large	PM-KL-4A	100	45,100
210	L7	Devipada	Paid Middle	Kiosk Large	PM-KL-4B	100	45,100
211	L7	Devipada	Unpaid South	Kiosk Large	US-KL-1A	65	22,815
212	L7	Devipada	Unpaid South	Kiosk Large	US-KL-1B	65	22,815
213	L7	Devipada	Unpaid South	Kiosk Large	US-KL-1C	91	31,941
214	L7	Devipada	Unpaid South	Kiosk Small	US-KS-1	26	13,000
215	L7	Devipada	Unpaid South	Kiosk Small	US-KS-2B	26	9,100
216	L7	Magathane	Unpaid North	Kiosk Small	UN-KS-1A	26	11,726
217	L7	Magathane	Paid Middle	Kiosk Large	PM-KL-1A	100	70,100
218	L7	Magathane	Paid Middle	Kiosk Large	PM-KL-1B	100	70,100
219	L7	Magathane	Paid Middle	Kiosk Large	PM-KL-2B	100	35,100
220	L7	Magathane	Paid Middle	Kiosk Large	PM-KL-3A	100	35,100
221	L7	Magathane	Paid Middle	Kiosk Large	PM-KL-3B	100	35,100
222	L7	Magathane	Paid Middle	Kiosk Medium	PM-KM-1B	50	17,550
223	L7	Magathane	Paid Middle	Kiosk Medium	PM-KM-1C	50	17,550
224	L7	Magathane	Paid Middle	Kiosk Medium	PM-KM-1D	50	40,000

Applicant may apply for units at or above the Base Price mentioned in the inventory list.

Annexure 6: Inventory of commercial spaces available

SN	Line	Station	Area	Format	Layout Unit No.	Usable Area (sqft)	Base Rate (In Rs.)
225	L7	Magathane	Paid Middle	Kiosk Large	PM-KL-4A	100	70,100
226	L7	Magathane	Paid Middle	Kiosk Large	PM-KL-4B	100	70,100
227	L7	Magathane	Unpaid South	Kiosk Small	US-KS-1A	26	11,726
228	L7	Poisar	Unpaid North	Kiosk Large	UN-KL-1	65	38,000
229	L7	Poisar	Unpaid North	Kiosk Large	UN-KL-2	65	38,000
230	L7	Poisar	Unpaid North	Kiosk Small	UN-KS-2	26	32,000
231	L7	Poisar	Paid Middle	Kiosk Large	PM-KL-1B	100	45,100
232	L7	Poisar	Paid Middle	Kiosk Large	PM-KL-2A	100	35,100
233	L7	Poisar	Paid Middle	Kiosk Large	PM-KL-2B	100	35,100
234	L7	Poisar	Paid Middle	Kiosk Large	PM-KL-3A	100	35,100
235	L7	Poisar	Paid Middle	Kiosk Large	PM-KL-3B	100	35,100
236	L7	Poisar	Paid Middle	Kiosk Medium	PM-KM-1A	50	15,050
237	L7	Poisar	Paid Middle	Kiosk Medium	PM-KM-1B	50	15,050
238	L7	Poisar	Paid Middle	Kiosk Medium	PM-KM-1C	50	15,050
239	L7	Poisar	Paid Middle	Kiosk Medium	PM-KM-1D	50	15,050
240	L7	Poisar	Paid Middle	Kiosk Large	PM-KL-4A	100	45,100
241	L7	Poisar	Paid Middle	Kiosk Large	PM-KL-4B	100	45,100
242	L7	Poisar	Paid Middle	Kiosk Large	PM-KL-5	65	22,815
243	L7	Poisar	Unpaid South	Kiosk Small	US-KS-1A	26	11,115
244	L7	Akurli	Unpaid North	Kiosk Large	UN-KL-1	65	39,000
245	L7	Akurli	Paid Middle	Kiosk Large	PM-KL-1A	100	45,100
246	L7	Akurli	Paid Middle	Kiosk Large	PM-KL-1B	100	45,100
247	L7	Akurli	Paid Middle	Kiosk Large	PM-KL-2A	100	35,100
248	L7	Akurli	Paid Middle	Kiosk Large	PM-KL-2B	100	38,000
249	L7	Akurli	Paid Middle	Kiosk Large	PM-KL-3A	100	35,100
250	L7	Akurli	Paid Middle	Kiosk Large	PM-KL-3B	100	35,100
251	L7	Akurli	Paid Middle	Kiosk Medium	PM-KM-1A	50	15,050
252	L7	Akurli	Paid Middle	Kiosk Medium	PM-KM-1B	50	15,050

Applicant may apply for units at or above the Base Price mentioned in the inventory list.

Annexure 6: Inventory of commercial spaces available

SN	Line	Station	Area	Format	Layout Unit No.	Usable Area (sqft)	Base Rate (In Rs.)
253	L7	Akurli	Paid Middle	Kiosk Medium	PM-KM-1C	50	15,050
254	L7	Akurli	Paid Middle	Kiosk Medium	PM-KM-1D	50	15,050
255	L7	Akurli	Paid Middle	Kiosk Large	PM-KL-4A	100	45,100
256	L7	Akurli	Paid Middle	Kiosk Large	PM-KL-4B	100	45,100
257	L7	Akurli	Paid Middle	Kiosk Large	PM-KL-5	65	22,815
258	L7	Akurli	Unpaid South	Kiosk Large	US-KL-1	65	39,000
259	L7	Akurli	Unpaid South	Kiosk Large	US-KL-2	65	32,500
260	L7	Akurli	Unpaid South	Kiosk Small	US-KS-1B	26	13,000
261	L7	Kurar	Unpaid North	Kiosk Large	UN-KL-1	65	42,250
262	L7	Kurar	Unpaid North	Kiosk Small	UN-KS-1	26	15,600
263	L7	Kurar	Paid Middle	Kiosk Large	PM-KL-1A	100	45,100
264	L7	Kurar	Paid Middle	Kiosk Large	PM-KL-1B	100	45,100
265	L7	Kurar	Paid Middle	Kiosk Large	PM-KL-2A	100	35,100
266	L7	Kurar	Paid Middle	Kiosk Large	PM-KL-2B	100	35,100
267	L7	Kurar	Paid Middle	Kiosk Large	PM-KL-3A	100	36,000
268	L7	Kurar	Paid Middle	Kiosk Large	PM-KL-3B	100	35,100
269	L7	Kurar	Paid Middle	Kiosk Medium	PM-KM-1A	50	15,050
270	L7	Kurar	Paid Middle	Kiosk Medium	PM-KM-1B	50	15,050
271	L7	Kurar	Paid Middle	Kiosk Medium	PM-KM-1C	50	15,050
272	L7	Kurar	Paid Middle	Kiosk Medium	PM-KM-1D	50	15,050
273	L7	Kurar	Paid Middle	Kiosk Large	PM-KL-4A	100	45,100
274	L7	Kurar	Paid Middle	Kiosk Large	PM-KL-4B	100	45,100
275	L7	Kurar	Unpaid South	Kiosk Large	US-KL-1	65	39,000
276	L7	Kurar	Unpaid South	Kiosk Small	US-KS-2	26	11,111
277	L7	Dindoshi	Unpaid North	Kiosk Large	UN-KL-1	65	38,000
278	L7	Dindoshi	Unpaid North	Kiosk Small	UN-KS-1B	26	6,526
279	L7	Dindoshi	Paid Middle	Kiosk Large	PM-KL-1A	100	45,100
280	L7	Dindoshi	Paid Middle	Kiosk Large	PM-KL-1B	100	45,100

Applicant may apply for units at or above the Base Price mentioned in the inventory list.

Annexure 6: Inventory of commercial spaces available

SN	Line	Station	Area	Format	Layout Unit No.	Usable Area (sqft)	Base Rate (In Rs.)
281	L7	Dindoshi	Paid Middle	Kiosk Large	PM-KL-2A	100	35,100
282	L7	Dindoshi	Paid Middle	Kiosk Large	PM-KL-2B	100	35,100
283	L7	Dindoshi	Paid Middle	Kiosk Large	PM-KL-3A	100	35,100
284	L7	Dindoshi	Paid Middle	Kiosk Large	PM-KL-3B	100	35,100
285	L7	Dindoshi	Paid Middle	Kiosk Medium	PM-KM-1A	50	15,050
286	L7	Dindoshi	Paid Middle	Kiosk Medium	PM-KM-1B	50	15,050
287	L7	Dindoshi	Paid Middle	Kiosk Medium	PM-KM-1C	50	15,050
288	L7	Dindoshi	Paid Middle	Kiosk Medium	PM-KM-1D	50	15,050
289	L7	Dindoshi	Paid Middle	Kiosk Large	PM-KL-4A	100	45,100
290	L7	Dindoshi	Paid Middle	Kiosk Large	PM-KL-4B	100	45,100
291	L7	Dindoshi	Unpaid South	Kiosk Large	US-KL-1	65	38,000
292	L7	Dindoshi	Unpaid South	Kiosk Small	US-KS-1A	26	6,526
293	L7	Aarey	Unpaid North	Kiosk Small	UN-KS-1B	26	11,726
294	L7	Aarey	Paid Middle	Kiosk Large	PM-KL-1A	100	70,100
295	L7	Aarey	Paid Middle	Kiosk Large	PM-KL-2A	100	35,100
296	L7	Aarey	Paid Middle	Kiosk Large	PM-KL-2B	100	35,100
297	L7	Aarey	Paid Middle	Kiosk Large	PM-KL-3A	100	35,100
298	L7	Aarey	Paid Middle	Kiosk Large	PM-KL-3B	100	35,100
299	L7	Aarey	Paid Middle	Kiosk Medium	PM-KM-1A	50	17,550
300	L7	Aarey	Paid Middle	Kiosk Medium	PM-KM-1B	50	17,550
301	L7	Aarey	Paid Middle	Kiosk Medium	PM-KM-1C	50	17,550
302	L7	Aarey	Paid Middle	Kiosk Medium	PM-KM-1D	50	17,550
303	L7	Aarey	Paid Middle	Kiosk Large	PM-KL-4A	100	70,100
304	L7	Aarey	Paid Middle	Kiosk Large	PM-KL-4B	100	70,100
305	L7	Aarey	Unpaid South	Kiosk Large	US-KL-1	65	35,815
306	L7	Aarey	Unpaid South	Kiosk Large	US-KL-2A	65	35,815
307	L7	Aarey	Unpaid South	Kiosk Large	US-KL-2B	65	35,815
308	L7	Goregaon East	Unpaid North	Kiosk Large	UN-KL-1A	65	63,000

Applicant may apply for units at or above the Base Price mentioned in the inventory list.

Annexure 6: Inventory of commercial spaces available

SN	Line	Station	Area	Format	Layout Unit No.	Usable Area (sqft)	Base Rate (In Rs.)
309	L7	Goregaon East	Unpaid North	Kiosk Large	UN-KL-1B	65	38,000
310	L7	Goregaon East	Unpaid North	Kiosk Small	UN-KS-1	26	15,600
311	L7	Goregaon East	Paid Middle	Kiosk Large	PM-KL-1A	100	70,100
312	L7	Goregaon East	Paid Middle	Kiosk Large	PM-KL-1B	100	70,100
313	L7	Goregaon East	Paid Middle	Kiosk Large	PM-KL-2A	100	40,000
314	L7	Goregaon East	Paid Middle	Kiosk Large	PM-KL-2B	100	40,000
315	L7	Goregaon East	Paid Middle	Kiosk Large	PM-KL-3A	100	35,100
316	L7	Goregaon East	Paid Middle	Kiosk Medium	PM-KM-1B	50	17,550
317	L7	Goregaon East	Paid Middle	Kiosk Medium	PM-KM-1C	50	17,550
318	L7	Goregaon East	Paid Middle	Kiosk Medium	PM-KM-1D	50	54,000
319	L7	Goregaon East	Paid Middle	Kiosk Large	PM-KL-4A	100	70,100
320	L7	Goregaon East	Paid Middle	Kiosk Large	PM-KL-4B	100	70,100
321	L7	Goregaon East	Unpaid South	Kiosk Large	US-KL-1	65	39,000
322	L7	Goregaon East	Unpaid South	Kiosk Small	US-KS-1B	26	11,726
323	L7	Jogeshwari East	Unpaid North	Kiosk Large	UN-KL-1	65	55,250
324	L7	Jogeshwari East	Unpaid North	Kiosk Small	UN-KS-1B	26	26,000
325	L7	Jogeshwari East	Paid Middle	Kiosk Large	PM-KL-1A	100	70,100
326	L7	Jogeshwari East	Paid Middle	Kiosk Large	PM-KL-1B	100	70,100
327	L7	Jogeshwari East	Paid Middle	Kiosk Large	PM-KL-2A	100	40,000
328	L7	Jogeshwari East	Paid Middle	Kiosk Large	PM-KL-2B	100	47,000
329	L7	Jogeshwari East	Paid Middle	Kiosk Medium	PM-KM-1A	50	54,000
330	L7	Jogeshwari East	Paid Middle	Kiosk Medium	PM-KM-1C	50	17,550
331	L7	Jogeshwari East	Paid Middle	Kiosk Medium	PM-KM-1D	50	30,000
332	L7	Jogeshwari East	Paid Middle	Kiosk Large	PM-KL-3A	100	55,100
333	L7	Jogeshwari East	Paid Middle	Kiosk Large	PM-KL-3B	100	55,100
334	L7	Jogeshwari East	Unpaid South	Kiosk Large	US-KL-1	65	45,500
335	L7	Jogeshwari East	Unpaid South	Kiosk Small	US-KS-1B	26	11,726
336	L7	Mogra	Unpaid North	Kiosk Large	UN-KL-1	65	22,815

Applicant may apply for units at or above the Base Price mentioned in the inventory list.

Annexure 6: Inventory of commercial spaces available

SN	Line	Station	Area	Format	Layout Unit No.	Usable Area (sqft)	Base Rate (In Rs.)
337	L7	Mogra	Unpaid North	Kiosk Small	UN-KS-2	26	6,526
338	L7	Mogra	Paid Middle	Kiosk Large	PM-KL-1A	100	45,100
339	L7	Mogra	Paid Middle	Kiosk Large	PM-KL-1B	100	45,100
340	L7	Mogra	Paid Middle	Kiosk Large	PM-KL-2A	100	35,100
341	L7	Mogra	Paid Middle	Kiosk Large	PM-KL-2B	100	35,100
342	L7	Mogra	Paid Middle	Kiosk Medium	PM-KM-1A	50	15,050
343	L7	Mogra	Paid Middle	Kiosk Medium	PM-KM-1B	50	15,050
344	L7	Mogra	Paid Middle	Kiosk Medium	PM-KM-1C	50	15,050
345	L7	Mogra	Paid Middle	Kiosk Medium	PM-KM-1D	50	15,050
346	L7	Mogra	Paid Middle	Kiosk Large	PM-KL-3A	100	35,100
347	L7	Mogra	Paid Middle	Kiosk Large	PM-KL-3B	100	35,100
348	L7	Mogra	Paid Middle	Kiosk Large	PM-KL-4A	100	35,100
349	L7	Mogra	Paid Middle	Kiosk Large	PM-KL-4B	100	35,100
350	L7	Mogra	Unpaid South	Kiosk Large	US-KL-1	65	22,815
351	L7	Mogra	Unpaid South	Kiosk Large	US-KL-2	65	22,815
352	L7	Mogra	Unpaid South	Kiosk Small	US-KS-2	26	6,526
353	L7	Gundavali	Paid Middle	Kiosk Medium	PM-KM-1B	50	17,550
354	L7	Gundavali	Paid Middle	Kiosk Medium	PM-KM-1D	50	45,000
355	L7	Gundavali	Paid Middle	Kiosk Large	PM-KL-4A	100	70,100

Applicant may apply for units at or above the Base Price mentioned in the inventory list.

Annexure 7: Draft License Agreement

< To be executed on non-judicial stamp paper of Rs 500, stamped in accordance with the Stamp Act of the Government of Maharashtra >

This 'LICENSE AGREEMENT' is made on this _____ day of two thousand twenty three between Maha Mumbai Metro Operation Corporation Limited (MMMOCL), a company incorporated under the provisions of the Companies Act, 1956/2013, having its corporate office at 4th Floor, NAMTTRI Building, Adjoining New MMRDA Building, Bandra Kurla Complex, Bandra East, Mumbai 400051, hereinafter referred to as the 'LICENSOR' on the one part, represented by _____ (name and designation of representing officer), MMOCL, which term shall, unless excluded by or repugnant to the context, be deemed to include its representatives, successors and assignees.

And,

_____ (Name of the successful Bidding Entity), Company / Corporation / Trust incorporated / registered under the provisions of the _____ Act, _____ bearing registration number _____ and having its registered office at _____ represented by _____ (name and designation of representing officer) on the other part, hereinafter referred to as the 'LICENSEE', which term shall, unless excluded by or repugnant to the context, be deemed to include its representatives, successors and assignees.

WHEREAS,

The Licensor, with a view to augment its revenues through Non-Fare Revenue initiatives had invited proposals (via Request For Proposal no. MMMOCL/NFBR/Policy /[*] dated [*], 2021 (the 'RFP') from interested parties for licensing spaces for retail and other commercial uses at Mumbai Metro Line 2A & 7 stations. After evaluation of the bids, the Licensor has selected _____ as the Licensee for licensing spaces at Mumbai Metro Line 2A & 7 on "as is where is basis".

The Licensor has agreed to provide to the Licensee spaces for retail and other commercial uses on payment of License Fee and other specified utility charges to the Licensor (the 'License') on the terms and conditions mentioned in this License Agreement.

The Licensee is allotted spaces at Mumbai Metro Line 2A & 7 stations as per the terms and conditions in the Policy. The Commercial Plan shall be prepared by the Licensee and submitted for approval to the Licensor. Post approval from the Licensor, the Licensee shall implement the approved Commercial Plan.

It is deemed necessary and expedient to enter into this License Agreement to record the terms and conditions of the said Agreement.

NOW THEREFORE,

In consideration of the mutual promise and consideration set out herein, the Licensor and the Licensee (hereinafter collectively called 'Parties') witness and hereby agree as follows:

1. The following documents hereto shall be deemed to form an integral part of this License Agreement:
 - a. The Letter of Acceptance (LOA) issued by the Licensor in favour of the successful Bidding Entity
 - b. All the submission Proposals and documents made by the Licensee as part of the Policy submission
 - c. Corrigendum to the Policy if issued by the Licensor
 - d. Policy No. MMMOCL/NFBR/Policy/[*] dated [*], 2024 in its entirety along with all its Annexures

2. The Licensee shall submit the following before signing of the License Agreement
 - i. Performance Bank Guarantee as per prescribed format in the Annexure
 - ii. Indemnity Bond as per prescribed format in the Annexure
 - iii. Solvency Certificate as per prescribed format in the Annexure
3. The Licensor shall provide the Licensee with a bare concrete floors on “as is where is basis” without any structural fitment
4. The Licensee shall be entitled to sub-license the licensed space to any person or entity (the “Sub-Licensee”) after the prior approval of the Licensor
5. Except for the activities banned by law or government regulations for usage of the licensed spaces, the licensed spaces can be used for any of the following purposes –
 - i. Food & Beverage: kiosks, stalls, food courts, etc.
 - ii. Product retail: convenience stores, supermarkets, pharmacy, bookstores, florists, speciality stores for sports, toys, fashion, etc.
 - iii. Service retail: salons, coaching classes, gyms, mobile top-up stores, etc.
 - iv. Office: bank branches, coworking spaces, courier centres, etc.
 - v. E-commerce pickup points
 - vi. ATMs, vending machines
 - vii. Any other commercial categories

The Licensee shall ensure proper storage of the packaged products ensuring that there is no contamination or decay of products or raw materials or goods

6. Activities Not Permitted
 - i. Any product / service the sale of which is unlawful / illegal or deemed unlawful under any Indian act or legislation
 - ii. Any product, the storage and sale of which may lead to or be considered as a fire hazard, such as firecrackers, industrial explosives, chemicals, etc.
 - iii. Open sale of alcohol, tobacco and tobacco products is not permitted to discourage consumption at the metro stations / trains, however selling of the same in enclosed packets for pickup only shall be permitted
 - iv. Use of open flame for cooking or any other purposes

7. Licensee shall ensure that –
 - a. Activities undertaken in the licensed spaces neither interferes with metro activities nor causes any inconvenience to metro commuters
 - b. In case the activities in the licensed spaces are found to interfere / infringe with metro activities or commuter movement, the Licensor reserves the right to direct the Licensee not to undertake such activities any further at any stage during the license period.
 - c. The decision of the Licensor in this regard shall be final and binding upon the Licensee and the Licensee shall not claim any loss or damages in this regard.
 - d. In case of serious accident caused due to negligence of the Licensee, resulting in injury, death to commuters or the Licensor's employees or loss to the Licensor's property, the Licensor shall be entitled to terminate the License Agreement besides the Licensee will be liable to pay compensation/ damages as per law.
8. The License for licensing of spaces shall be valid for the duration of the 'License Period' with the specified 'Lock-in Period' from the date of Commissioning of Metro', which shall be communicated by the Licensor to the Licensee, unless terminated earlier as per the terms and conditions in the Policy.
9. The time period for the Licensee to design and install fixtures prior to the Commissioning of Metro will not be a part of the License Period.
10. Licensee shall be provided sufficient time before the Commissioning of Metro operations to install fixtures as per Summary of Key Commercial Terms.
11. The Licensee shall equip himself with all necessary permits, licenses and such other permissions as may be required under the law in force at any time with regard to the operation of the said License.
12. All structural member / bolts etc. shall be galvanized or any better method to be used as per the latest technology, industry standard for safety consideration.
13. The Licensee shall pay all applicable taxes, levies including municipal levies on advertising and insurance premiums payable under Applicable Law, during its performance under the License Agreement.
14. After successful completion of the License Period, the Licensee shall be provided right to match the highest bid of the subsequent Policy if they participate in the bidding process and their bid is within 10% of the highest bid in order to renew the License with the updated terms and conditions as decided by the Licensor.

15. If the Licensee is desirous of terminating the License before completion of the License Period or the Licensor decides to terminate the License before the completion of the License Period, such termination shall be in accordance with the terms and conditions mentioned in the Policy and this License Agreement
16. The Licensee shall, in consideration of the License granted by the Authority, pay to the Authority Licensee Fee and furnish Performance Security as detailed in the Summary of Key Commercial Terms.
17. The payment to the Authority by the Licensee shall be completed by the Due Date as per Summary of Key Commercial Terms failing which interest at the rate of 12% per annum shall be charged for a period of 30 days and 18% per annum thereafter.
18. In case, default persists on the 31st day counted from due date, the Authority shall issue a notice of intent to terminate the License.
19. After expiry of notice period of 30 days, if the default still persists, the Authority shall have the right to terminate the License forthwith or grant the Licensee further extension in case of exceptional circumstances subject to the Authority's assessment.
20. The Licensee shall make payment of License Fee by demand draft / banker's cheque (or NEFT / RTGS / IMPS) in favour of Maha Mumbai Metro Operation Corporation Limited, payable in Mumbai.
21. In the event of non-receipt of any invoice, the Licensee shall collect the same from the office of the Licensor.
22. The Licensee has furnished Interest Free Performance Security, a sum equal to _____ vide Bank Guarantee No. _____ dated _____ or via Demand Draft dated _____ drawn on _____ Bank in favour of Maha Mumbai Metro Operation Corporation Limited with a validity of _____ months.
23. In case the Licensee fails to furnish the prescribed BG/ Demand Draft from time to time, the Authority shall issue a notice with a 15-day cure period; if the Licensee still fails to furnish the BG/ Demand Draft, then the Authority should have the right to terminate the License and Licensee shall forfeit the License Fee paid in advance.
24. The Licensor shall not be responsible for any loss or damage caused to the Licensee on any account whatsoever.

25. It shall be the responsibility of the Licensee at all time during the currency of the License Agreement to obtain adequate fire, theft and burglary insurance coverage in respect of all its movable and immovable assets in the licensed spaces and the Licensor shall not be responsible for any loss or damage caused to the Licensee on any account whatsoever.
26. The Licensee shall use the designated space only for the bona fide purpose as mentioned in the Policy and this License Agreement, and for no other purpose.
27. In the event of failure, negligence or breach, in the opinion of the Licensor, on the part of the Licensee in complying with all or any of the conditions of the License Agreement, the Licensor shall be entitled and be at liberty to terminate the License forthwith; the Licensor has the right to invoke the Performance Security / recover outstanding dues as per the clauses mentioned in the Policy.
28. The Licensor and the Licensee further agree that they are bound by the terms and conditions of the Policy including any corrigendum thereof. In case of any conflict between the Policy (including any corrigendum and / or addendum thereof) and this License Agreement, the latter shall prevail insofar as the spirit of the Policy is not affected thereby.
29. The Policy and Corrigendum, are an integral part of this License Agreement and are annexed to this agreement.
30. If the Licensee neglects or fails to do anything agreed to do as per the terms of the License Agreement, the Licensor may serve a notice on the Licensee asking them to do things agreed upon as aforesaid and on their neglect or failure to do so, cause the same to be done by the Licensor and recover the costs thereof from the Licensee without prejudice to any other right the Licensor may have on account of such defaults.
31. The Licensee shall observe and adhere to all the relevant rules and regulations and other policies approved or any amendments thereto from time to time by the Licensor / local authority / concerned competent authority.
33. The Licensee shall throughout the License Period have full regard for safety of all persons entitled to be upon the site in an orderly state appropriate to the avoidance of danger to such persons during the erecting, fixing, cleaning, removing, refixing, painting and maintenance work.
34. The Licensee shall provide and maintain adequate lights, guards, warning signs when and wherever required.

35. The Licensee shall, indemnify the Licensor and keep it indemnified for the entire License Period against all claims, actions, demands, losses, costs, charges and expenses which the Licensor may incur or be put to or which may arise by reason of the exercise of the right to commercialize spaces hereby granted including claims or actions arising out of any space outlet being challenged or held to be libellous or defamatory or any part thereof from any clause whatsoever and also for any claim made by any local Authority or any other person in respect thereof or any claim for rates or taxes levied in respect of anything done under this License Agreement.
36. The Licensor shall not be liable to pay any compensation in case the Licensee, his servants, agents or any other person meets with an accident or in case any injury is caused to or suffered by any one of them or any third party or to any property whatsoever, whether owing to the negligence or carelessness or any other conduct of the Licensee, its agents or servants and others or in case of injury due to any act of God or any circumstances beyond the control of the Licensor, while the work under the License Agreement is undertaken by the Licensee, it shall be the liability of the Licensee, who shall keep the Licensor indemnified in that respect throughout.
37. Any sum of money due and payable to the Licensee including any sum returnable to the Licensee under this License Agreement may be appropriated by the Licensor and set off against any claim of the Licensor for the payment of any sum of money arising out of or under any other contract made by the Licensee with the Licensor.
38. The Licensor may recover the balance outstanding dues, if are more than Interest Free Performance Security, from the other contracts of the Licensee with the Licensor. Balance outstanding dues, if are more than Interest Free Performance Security, shall also be recoverable from the Licensee before Licensee is permitted to remove their installations or else the Licensor will seize their property treating at "Zero" or "Nil" value. The Licensor shall be free to dispose off the said property/ goods in whatsoever manner as it deems fit. Licensee shall have no claim for compensation or damages in this regard.
39. All cost charges and expenses of and incidental to drawing, engrossing and completing the agreement in duplicate including stamp duty and registration charges shall be borne and paid by the Licensee. The original agreement shall be with the Licensee and duplicate copy shall be with the Licensor.

40. The Licensee shall have the right to display signage(s) of suitable size for displaying its logo / generic name. The signage may be illuminated or non-illuminated at the Licensee's option, however it shall need to confirm to all governmental laws, regulations or ordinance relevant thereto. The Licensee shall also need to obtain a written approval from the Licensor before putting up any form of signage and the Licensor reserves the right to refuse or to suggest an alternation to the same. The size, shape, location, etc. of signage are subject to the design guidelines given in the Annexures. Signage should be used only for the business being run by the Licensee in the licensed premises. In addition, the Licensee shall also be required to use materials as per standards prevalent in global metro networks and in-line with the design guidelines given in the Annexures, for which he shall seek necessary approval from the Licensor.
41. No third-party advertisement in any format shall be permitted at the licensed space. However, the Licensee shall be allowed to use interior and exterior of the licensed spaces for display of advertisement only related to the business / commodity being run / sold by the Licensee.
42. The Licensee shall need to obtain a written approval from the Licensor by way of a notice before putting up any form of signage/ advertisement within / outside their premises and the Licensor reserves the right to refuse or to suggest an alternation to the same. The signage/ advertisement shape and location, etc. shall be as per the design guidelines provided in the Annexures.
43. Placement of signage / advertisement without the permission of the Licensor or placement in non approved locations shall attract a penalty of Rs. 5,000/- per signage/ advertisement on the first occasion and Rs. 50,000/- per signage/ advertisement on the second occasion. In case of persistence default, the Licensor reserve the right to terminate the agreement and invoking the Performance Security and advance license fees paid in its favour.
44. The Licensor shall not unreasonably interfere with the signage/ advertisement plan. If the Licensor is not satisfied and raises any objections, the Licensee shall be required to appropriately amend/ modify his scheme within a reasonable timeframe and seek the Licensor's approval once again.
45. Except where otherwise specified in the License Agreement and subject to the powers delegated to him / her by the Licensor in force, the decision of Director (Finance) shall be final, conclusive and binding on all Parties to the License for all questions relating to the meaning and interpretation of the License conditions or regarding any other question, claim, right, matter or things whatsoever arising out of or relating to the License.

46. If the Licensee is not satisfied with the order passed by Director (Finance) as aforesaid, the Licensee may within 30 days of receipt by him / her of any such order, appeal against it to the Managing Director (MD) of the Licensor who, if convinced that prima facie the Licensee's claim rejected by Director (Finance) is not frivolous and that there is some substance in the claim of the Licensee and would merit a detailed examination through a suitable committee appointed for the purpose by the MD if necessary and in that case, decision taken by the committee shall be finalized by the Licensor and same shall be binding to the Licensee.
47. If the Licensee is still not satisfied with the resolution, then legal action may be initiated where courts of Mumbai shall have the exclusive jurisdiction.
48. The Licensor shall, by not less than 30 days, give a written notice of termination to the Licensee after the occurrence of any of the following Events of Default -
 - a. If the Licensee fails to remedy a failure in the performance of their obligations under the License, as specified in a notice of suspension within 30 days of receipt of such notice of suspension or within such further period as MMMOCL may have subsequently approved in writing;
 - b. If the Licensee becomes insolvent or bankrupt or enters into any agreements with their creditors for relief of debt or takes advantage of any law for the benefit of debtors or go into liquidation or receivership whether compulsory or voluntary;
 - c. If the Licensee fails to comply with any final decision reached as a result of arbitration proceedings;
 - d. If the Licensee submits to MMMOCL a statement which has a material effect on the rights, obligations and interests of MMMOCL and which the Licensee knows to be false;
 - e. If, as a result of Force Majeure, the Licensee is unable to perform a material portion of the License for a period of not less than 60 days;
 - f. If the Licensee, in the judgment of MMMOCL has engaged in corrupt or fraudulent practices in competing for or in executing the License;
49. If the Licensee terminates their License Agreement within the Lock-in Period, their furnished Performance Security shall be invoked by the Licensor.
50. If the Licensee wants to terminate their License Agreement after the Lock-in Period, they shall give an advance notice prior to the termination to the Licensor as per Summary of Terms.

51. In case of abrupt termination without an advance notice as per Summary of Terms to the termination by the Licensee, the Licensor shall invoke their furnished Performance Security.
52. Adjustments for damages –
 - i. At the time of the successful completion of the License Period or at the time of termination, the Licensee shall dismantle and remove all fixtures and debris ensuring no damage to the station structures, utilities and finishes and restore the space to its original condition as was handed over by the Authority at the beginning of the License Period.
 - ii. After the Licensee has removed all the fixtures, the Licensor will take 2 weeks to assess the cost of the damages caused by the Licensee if any and shall bill the Licensee for the same payable within 15 days.
 - iii. Interest Free Performance Security furnished by the Licensee shall be returned to the Licensee after all payments against damages and other dues payable to the Licensor are recovered.
 - iv. The Authority reserves the right to recover the outstanding dues from the other contracts between the Licensee and the Licensor, if any.
 - v. The uninstallation should be initiated 1 month prior to the end of the License Period / termination date such that the above process is completed by the time License Period / License Agreement ends.
53. The Licensee shall vacate the commercial spaces licensed out by the due date as per the above process, otherwise the Licensor shall take over the possession of the property goods and all the belongings/ inventory/ property/ installations/ fittings/ goods etc. shall be evacuated and vested in the Licensor considering at Zero/ Nil value. Further the Licensor shall be free to dispose off these goods by any procedure as deemed fit. The Licensee hereby voluntarily and unequivocally agrees not to seek any claim, damages, compensation or any other consideration thereafter in future in this regard.
54. Upon termination or expiry of this License, all rights and obligations of the Parties hereunder shall cease, except -
 - a. Such rights and obligations as may have accrued on the date of termination or expiration
 - b. The obligation of confidentiality
 - c. Any right which a Party may continue to have under applicable law

55. The Licensee shall be entitled to sub-license the licensed space to any person or entity after prior approval of the Licensor, the Sub-Licensee. However, all liabilities under the License Agreement will remain with the Licensee.
56. The sub-license shall however be for the use of the licensed spaces during the subsistence of the License Period only, with a clear stipulation that all such sub-licenses granted shall be at maximum co-terminus with the License Agreement.
57. All contracts, agreements or arrangements with Sub-Licensee shall specifically stipulate this covenant of termination of the rights of the Sub-Licensees, and further that such Sub-Licensee shall not have any claim or seek any compensation from the Licensor for such termination.
56. The Licensor shall provide the Licensee with plain / concrete floors on “as is where is basis” without any structural fitment.
57. The licensed space is located at Concourse and Concourse 1 levels within the stations, no such space is available at the platform level.
58. The licensed space is required to be furnished / developed by the Licensee.
59. The Licensee shall submit all layouts, designs, proposed uses, specification of materials including but not limited to construction, internal partitions, fire detection & fighting, flooring, lighting, electrical, signages, advertisement panels, etc. in-line with the design guidelines specified in the Annexures and the same shall be sent for approval of the Licensor before start of any works inside the licensed spaces.
60. The Licensor reserves the right not to give approval if it deems such works may act as a hindrance in the smooth functioning of its operations at the station.
61. The Licensee shall procure and install fixtures in consultation with the Licensor without damaging the station structures, utilities or finishes; in case of damage the Licensor will recover the cost from the Licensee.
62. All materials used, including electrical materials should be fire resistant as per the design guidelines provided in the Annexures, and in this connection the approval of the Licensor must be taken before commencement of the installation.
63. The Licensee shall be required to execute all works as required for the commercial use in the licensed spaces without damaging any load bearing / structural members and any services / utilities, etc.
64. The Licensee shall have to carry out all internal finishing works including internal partitions, utilities, doors, flooring, plastering, painting, etc.

65. All necessary modification shall be carried out by the Licensee at its own cost after taking approval of the plans from the Licensor, if there is any damage to any structure / asset of the Licensor, the cost shall be borne by the Licensee.
66. The Licensee shall be solely responsible for procuring all the permissions / licenses / NOCs, etc. required from the statutory / regulatory / civic authorities concerned, to be able to use the licensed spaces for desired commercial purposes; the Licensor shall facilitate where required.
67. The Licensee will operate, manage, maintain and upkeep the entire licensed space with adequately trained and experienced staff and necessary equipment at its own cost.
68. Incidental expenses related to planning, installation, repair and O&M of the fixtures will be borne by the Licensee.
69. Licensee shall ensure strict adherence to Permit-to-work (PTW) process and corresponding provisions in list of 'event of default' and safety guidelines of the Licensor.
70. Right of Way to the station shall be provided to the Licensee as per pre-agreed schedule for operations and maintenance (O&M).
71. Non-intrusive O&M shall be permitted during non-peak hours, while intrusive O&M shall be permitted during non-operational hours (12 am to 5 am) barring emergency situations, intrusive is interpreted as interfering with core station operations.
72. The Licensor shall provide security at stations which will oversee all station assets including fixtures at commercial spaces, however, the Licensor shall not be liable for any theft or damage to the fixtures despite the security provided.
73. All fire-fighting equipment, pumps, common piping, etc. required to be installed outside the licensed spaces for firefighting arrangements will be provided by the Licensor up to a common from where the Licensee shall make further arrangements inside the licensed spaces.
74. Inside the licensed spaces, all firefighting installations, if any, including fire alarms and smoke detection systems shall be arranged by the Licensee and integrated in seamless manner with the Licensor's system.
75. Such fire-fighting arrangements would conform to the National Building Code, relevant Building Byelaws / Indian Standards (IS) Codes, Fire Safety (Fire Prevention) Rules and any other instructions issued by the Licensor in this regard.

76. Only after certification by the fire officer / authorized representative of the Licensor, shall the Licensee be permitted to occupy and use the licensed spaces for commercial purposes.
77. The fire clearance before and after installation of the fire detection / fire-fighting system shall be obtained by the Licensee for the licensed spaces.
78. The Licensor reserves the right to inspect the licensed spaces at any time during the license period in connection with fire-fighting readiness.
79. The Licensor may also issue directives in this regard, which shall have to be adhered to and complied by the Licensee.
80. Any additional works, as may be indicated on this account, will also be carried out by the Licensee at its own cost.
81. No claim for damages or compensation for inconvenience in this regard will be entertained by the Licensor.
82. The Licensee shall at all times adhere to all provisions of the Metro Railway (Operation and Maintenance) Act, 2002 and amendments thereto and shall also comply with all notices and circulars issued by the Licensor in this regard.
83. Under no circumstances shall the tendered space or facilities constructed or installed at the licensed space be mortgaged, charged or otherwise put under any lien (including negative lien), charge or encumbrance be created or agreed to be created in favour of any person, including the lenders.
84. The Licensee's attention is drawn to the Contract Labour (Regulation and Abolition) Act, 1970 and the Maharashtra Contract Labour (Regulation and Abolition) Rules, 1971. The Licensee shall comply with the provisions of the said Act and Rules framed there under.
85. The Licensor shall provide provisions for electric and to the extent possible data connectivity for all units across Line 2A and 7, drainage and plumbing shall be provided only for blocks at Line 2A as indicated in Typical Station Layout in this Policy.
86. The internal distribution of these utilities as required for the licensed spaces shall be installed by the Licensee at its own cost.
87. The Licensee will have to make its own arrangements including installation of meters, storage and purification of water at its own cost after taking all the necessary approvals.
88. Utility charges for electricity, data, water to be billed on actuals on a quarterly basis payable by the Licensee within the prescribed due date.

89. Housekeeping and O&M of Licensee's respective units shall be done by the Licensee.
90. Licensee's O&M staff is expected to monitor the health of the fixtures periodically and flag off any issues pertaining to seepages, etc. to the Licensor which will then take necessary remedial action.
91. The Licensee shall remove the debris from the site of work within 24 hours from the date of written instructions to the Licensee to that effect, failing which the Licensor will remove the same by engaging any other Entity or departmentally and the cost of the same shall be recovered as stipulated in 'Conditions of Contract' from any money due to them, such decision shall not form the subject matter of any dispute.
92. Garbage and debris should be disposed of as per pollution control guidelines given by the state government and local bodies.
93. The discharge of all wastes including the drainage shall also be arranged by the Licensee at its own costs and in this connection, it shall follow all the directives as may be issued by the Licensor.
94. The Licensee shall ensure that all persons employed are well groomed and sanitized and behave in an orderly and disciplined manner and that the said employees are prohibited from carrying on any unlawful, unfair activities or demonstrations.
95. The Licensee shall submit the details/ bio data of personnel to whom it intends to employ/ deploy for carrying out the work. The personnel deployed shall be decent, courteous and without any adverse or criminal background. In this connection, Licensee shall be required to furnish declaration to the Licensor with respect to all their personnel deployed. Further, in the Commercial Plan, Licensee shall submit police verification report in respect of all its personnel to the Authority. All the Licensee's personnel shall be required to possess ID card issued by the Licensor while working in the Licensor's premises as per prevailing procedure. Access inside the stations in paid areas shall be through smart cards as per prevailing applicable charges, in addition to the valid ID cards.
96. The property tax/ service charge applicable on the licensed spaces, if any, shall be paid by the Licensor as per applicable rates of concerned municipal corporations in advance. Subsequently, the aforementioned property tax/ service charge will be charged and recovered from the Licensee.

97. Further, the Licensor can impose the fine on the Licensee up to Rs.5,000/- per offence / per instance per licensed unit on the following offenses:
- a. Any staff of Licensee found in drunken condition/ indulging in bad conduct
 - b. Any staff of the Licensee found creating nuisance on duty
 - c. Improper maintenance and defacement of the metro property
 - d. Misbehaviour with staff and commuters of the Licensor
 - e. Not following safety and security norms as may be indicated by authorized representative of the Licensor
 - f. Any staff of the Licensee found without uniform and ID Card and/ or found creating nuisance on duty
 - g. Not following the instructions issued by the Licensor from time to time
 - h. Dishonour of drafts and cheques given by the Licensee in favour of the Licensor
98. No tenancy / sub-tenancy is being created by the Licensor in favour of Licensee under or in pursuance of this License Agreement and it is distinctly and clearly understood, agreed and declared by / between the parties hereto that:
- a. The Licensee shall not have or claim any interest in the said licensed units as a tenant / sub-tenant or otherwise
 - b. The rights, which Licensee shall have in relation to the said premises, are only those set out in this License Agreement
 - c. The relationship between the Licensor and Licensee under and / or in pursuance of this License Agreement is as between Principal and Principal. Consequently, neither Party shall be entitled to represent the other and/ or make any commitment on behalf of and/ or with traders or any other party. Furthermore, no relationship in the nature of partnership or association of persons is hereby being created or intended to be created between the Licensor on the one hand and Licensee on the other hand in connection with and/ or relating business to be operated by Licensee at the said premises.

Key Commercial Terms

Key Terms	Description
Contract Type	<ul style="list-style-type: none"> License Agreement between Licensor (MMMOCL) and Licensee (Selected Applicant)
Unit area available for Commercial Use	<ul style="list-style-type: none"> Kiosks up to 500 sqft area Blocks > 500 sqft area
List of units available for commercial use	<ul style="list-style-type: none"> MMMOCL shall publish a list of available inventory periodically; and MMOCL shall have the discretion to reconfigure the units in every subsequent published list
License Period	<ul style="list-style-type: none"> 5 (Five) Years extendible by another 5 (five) years for Kiosks 8 (Eight) Years extendible by another 5 (five) years for Blocks License Period shall start from the date of signing of the License Agreement
Lock-In Period	<ul style="list-style-type: none"> 1 Year for Kiosks, 2 Years for Blocks from the date of starting of Licence Fee period
Notice Period for surrender	<ul style="list-style-type: none"> 6 months' notice period from the date of intimation, subject to Lock-In Period. (Notice period can be given only after Lock-In period)
Extension Period	<ul style="list-style-type: none"> At the time of Expiry of License, the Authority shall have the discretion to extend the period by another 5 years at the License Terms decided by the Authority at that time, provided that the Licensee has met its obligations throughout the License Period to the satisfaction of the Authority
Pre-Commencement Period	<ul style="list-style-type: none"> 60 days from signing of the License Agreement License Fee is not payable for such period This period shall be used by the Licensee strictly for installation of fixtures and setting up operations; no revenue operations shall be allowed in this period License Fee shall be payable from the expiry of the Pre-Commencement Period or actual start of revenue operations of the Block / Kiosk, whichever is earlier
Sub-Licensing	<ul style="list-style-type: none"> Permitted; Licensee can monetize the Commercial Space through Sub-License contracts with interested parties

Key Terms	Description
Costs involved	<ul style="list-style-type: none"> • The Licensee shall be required to incur following costs during the License Term: <ul style="list-style-type: none"> • All installation & operations cost • License Fee, Common Area Maintenance Charges if any, and Performance Security • Installation of electricity meters, electricity charges on actuals as applicable • Cost of cabling, clamps, and all other material required for installation and operations • Applicable taxes including GST and stamp duty, all Statutory levies as applicable, Insurance Premium for equipment, if any
Electricity & Utilities	<ul style="list-style-type: none"> • Separate meter shall be procured and installed by the Licensee in its own name based on the recommendation by the Authority of the Electricity Distribution Company (Discom) or MMMOCL will provide the connection at common point from there Licensee will lay the cable up to the kiosk/Block at his own cost • Licensee shall be responsible to co-ordinate all the power supply related arrangements • Utility charges for electricity to be paid directly by the Licensee to the Discom • Licensee shall be responsible to make provisions on its own for their earthing requirements.
Implementation Plan	<ul style="list-style-type: none"> • Licensee is required to prepare the Implementation Plan within 15 days of issue of LOA and submit to MMMOCL for approval • MMMOCL will respond to the plan within 15 days of submission • If there is a delay on part of MMMOCL to revert to the plan, then there will be commensurate adjustment to the Pre-Commencement Period • However, if there is any delay on part of the Licensee, then there will be no such adjustment of Pre-Commencement Period • Implementation Plan should include detailed architectural drawing of the kiosk / block including details of material used, electrical and other utility connections, fire extinguisher and sprinkler locations, etc. • Manager (Commercial) and / or Assistant Manager (Business Development) shall consult with the relevant officials at MMMOCL and its consultants if any, and provide the comments / approval to the Implementation Plan

Key Terms	Description
Revenue Model	<ul style="list-style-type: none"> • Fixed Rent / License Fee per unit per month payable by the Licensee as per the prescribed payment terms • No Revenue Sharing envisaged
Quote Parameter	<ul style="list-style-type: none"> • Applicants are required to Quote a lumpsum Rs per month (rounded off to the nearest Rupee) for each unit which they are applying for
Payment Terms	<ul style="list-style-type: none"> • License Fee payable quarterly in advance. • License Fees shall be escalated annually by 5% per year on previous year rental. • First invoice to be raised 30 days prior to the expiry of the Pre-Commencement Period • For subsequent quarters, the Authority will raise the invoice 1 month prior to the start of the quarter • Invoice shall be raised by 1st of the month payable by 30th of the same month. For e.g., for the Quarter starting from 1-April-2024 to 30-June-2024, Invoice will be raised on 1-March-2024 and same will be payable by 30-March-2024 • Licensee shall pay Common Area Maintenance (CAM) charge of Rs 5 per sqft per month (on quarterly basis) along with the License Fees which shall be escalated annually by 5% as detailed hereinabove. Garbage disposal of Kiosk/Block is responsibility of the Licensee • Utility charges for water, electricity etc., if any, to be billed on actuals on Quarterly basis along with the License Fee payable within the prescribed date
Performance Security	<ul style="list-style-type: none"> • Interest Free Performance Security to be furnished for an amount equal to 6-months License Fee for a validity of 12 months • Performance Security can be furnished in the form of a Demand Draft or Bankers Cheque or Bank Guarantee (BG) • The Licensee shall, 2 weeks prior to the expiry of the Performance Security, extend it by 12 months and augment the BG / furnish additional Demand Draft equal to 6-months License Fee of the subsequent year (adjusted for 5% escalation), till the end of the License Period • Failure to furnish the initial or subsequent Performance Security shall attract Cure Period clauses as specified in this Policy; if the BG is still not furnished within the Cure Period, then it shall be an Event of Default and shall lead to initiation of termination proceedings

1.1 Timelines

- 1.1.1 The follow timelines are required to be followed by the Licensee
- 1.1.2 MMMOCL shall not entertain any requests for delay in meeting these timelines on the part of the Licensee
- 1.1.3 MMMOCL shall provide commensurate extension of the Pre-Commencement Period for any delay in providing comments / approving the Implementation Plan

Timeline	Activity
L	Issue of Letter of Allotment (LOA) to the Selected Applicant
L + 7 days	Acceptance of LOA by the Applicant
L + 15 days	Furnishing of Performance Security (BG / DD)
A = L + 30 days	Signing of the License Agreement Start of the License Period Licensee to procure 2 nos. of stamp papers of Rs 500 each, print the draft agreement on it, sign and stamp the same and submit tit to MMMOCL for countersigning; post that Licensee to get the agreement notarized and 1 original copy shall be retained by MMMOCL and the other copy shall be retained by the Licensee
L + 30 days	Licensee to submit the Implementation Plan within 15 days issue of LOA MMMOCL shall provide comments / approve the plan within 15 days from date of receipt of the detail plan as mentioned in this document
A + 60 days	Pre-Commencement Period <ul style="list-style-type: none"> License Fee is not payable for this period . This period shall be used by the Licensee strictly for installation of fixtures and setting up operations; no revenue operations shall be allowed in this period License Fee shall be payable from the expiry of the Pre-Commencement Period or actual start of revenue operations of the Block / Kiosk, whichever is earlier (Invoice shall be raised 1 month prior to the expiry of the Pre-Commencement Period)
A + 1 year	Lock-In Period – Kiosk
A + 2 year	Lock-In Period – Blocks
A + 5 / 8 years	License Period for Kiosk/Block

1.2 License Period

- 1.2.1 The License Period shall be from the signing the agreement as per Summary of Key Commercial Terms, unless otherwise terminated by the Authority or surrendered by the Licensee.
- 1.2.2 Lock-in Period shall be from the date of commencement of the License Period as per Summary of Key Commercial Terms.
- 1.2.3 Pre-commencement time period is available to the Licensee as per Key Commercial Terms to design and install the infrastructure will not be counted as part of the License Period.
- 1.2.4 Any extension of area of the allotted Kiosk / Block, if allotted by the Authority, shall be on pro-rata basis, subject to the Authority's approval.
- 1.2.5 The License Period for any such extended space handed over / allotted during the License Period will be co-terminus with the original License Period of the License Agreement.

1.2 License Fee

- 1.2.1 The Licensee shall, in consideration of the License granted by the Authority, pay to the Authority Licensee Fee and furnish Performance Security as detailed in the Summary of Key Commercial Terms.
- 1.2.2 The payment of License Fee to the Authority by the Licensee shall be completed by the Due Date as per Summary of Key Commercial Terms failing which interest at the rate of 12% per annum shall be charged for a period of 30 days and 18% per annum thereafter.
- 1.2.3 In case, default persists on the 31st day counted from due date, the Authority shall issue a notice of intent to terminate the License.
- 1.2.4 After expiry of notice period of 30 days, if the default still persists, the Authority shall have the right to terminate the License forthwith or grant the Licensee further extension in case of exceptional circumstances subject to the Authority's assessment.

1.3 Performance Security

- 1.3.1 At the time of signing the License Agreement, the Selected Entity shall furnish Interest Free Performance Security to the Authority. Licensee shall furnish single Performance Security for all the units Licensed to it.
- 1.3.2 It shall be an irrevocable Bank Guarantee (BG) issued by a Nationalized or Commercial Bank or Demand Draft payable at branches of the said bank located in Mumbai.
- 1.3.3 In case the Licensee fails to furnish the prescribed BG/ Demand Draft from time to time, the Authority shall issue a notice with a 15-day cure period; if the Licensee still fails to furnish the BG/ Demand Draft within the cure period, then the Authority shall have the right to terminate the License and Licensee shall forfeit the Performance Security and License Fee paid in advance.

1.4 Other Payables

- 1.4.1 All statutory taxes including GST, municipal and other levies, insurance premium, as applicable to this License shall be billed by the Authority to the Licensee and shall be paid along with the License Fee for onward remittance to the relevant government authorities.
- 1.4.2 The Licensee shall save the Authority harmless from liability for any dues against the above; the Licensee indemnifies the Authority from any claims that may arise from the statutory authorities in connection with this License.
- 1.4.3 Payment of stamp duty for execution of License Agreement shall be borne by Licensee post adjudication.
- 1.4.4 The Licensee shall solely bear the cost of installation, operations, repair and maintenance of all fixtures installed at the units awarded.
- 1.4.5 Utility charges for electricity, data and water shall be billed by the Authority to the Licensee as per Summary of Key Commercial Terms.
- 1.4.6 Direct taxes on respective income shall be borne by the respective Parties.

Licensor and Licensee represent and warrant that they are authorized to execute this License Agreement.

In witness whereof, the Parties hereto have caused this License Agreement to be signed in their respective names as of the day and year first written above.

Authorized Signatory Sign & Stamp

For Maha Mumbai Metro Operation Corporation Limited (Licensor)

Name & Designation:

Phone & Email:

Authorized Signatory Sign & Stamp

For _____ (Licensee)

Name & Designation:

Phone & Email:

Witness:

- i. Name, Designation, Contact
- ii. Name, Designation, Contact

Note: Final Draft MLA will be shared to the successful applicant for further process of contract signing as per the agree terms and condition of the tender clause and the agreed Quoted Price.

Annexure 8: Performance Bank Guarantee

BANK GUARANTEE BOND TOWARDS PERFORMANCE SECURITY DEPOSIT

(On Stamp Paper of INR 500/-)

To,

Manager (Commercial)

Maha Mumbai Metro Operation Corporation Limited (MMMOCL)
2nd Floor, NAMTTRI Building, Adjoining New MMRDA Building,
Bandra Kurla Complex, Bandra East, Mumbai 400051

1. In consideration of the Maha Mumbai Metro Operation Corporation Limited (MMMOCL), a company registered under the Companies Act, 1956 / 2013, having its corporate Office at 2nd Floor, NAMTTRI Building, Adjoining New MMRDA Building, Bandra Kurla Complex, Bandra East, Mumbai 400051, (hereinafter called the 'MMMOCL', which expression shall unless repugnant to the subject or context include its successors and assignees), having agreed under the terms and conditions of Retail Policy (hereinafter called 'Policy') No. MMOCL/NFBR/RetailPolicy/[*] dated [*], 2023 and/or Letter of Acceptance No. [*] dated [*], 2023 and License Agreement made between [licensee name] (hereinafter called the 'LICENSEE', which expression shall unless repugnant to the subject or context include his heirs, executors, administrators and assignees / its successors and assignees), and MMOCL, hereinafter called "the said License Agreement" furnish a Deed of Guarantee as herein provided for INR _____ (Amount in figures and words) through our branch at _____ towards Performance Security for the due fulfilment by the Licensee of the terms and conditions contained in said License Agreement & Policy.
2. We, _____ (Name & Address of Bank), the Bank constituted and established under the Banking Companies (Acquisition and Transfer of Undertakings) Act, 1979 (hereinafter referred to as the said Bank) and having our Head Office at _____, hereby undertake to pay to MMOCL an amount not exceeding INR _____ (Amount in figures & words) against any loss or damage caused to or suffered or would be caused to or suffered by MMOCL by reasons of any breach by the said Licensee of any of the terms or conditions contained in the said Policy and/or License Agreement and to unconditionally pay the amount claimed by MMOCL on demand and without demur to the extent expressed.

3. We further agree that MMMOCL shall be the sole judge of whether the Licensee has committed a breach of any of the terms and conditions of the said License Agreement and the extent of the loss, damage, costs, charges and expenses caused to or suffered by or that may be caused to or suffered by MMMOCL on account thereof, and the decision of MMMOCL that the Licensee has committed such breach, and as to the amount or amounts of loss, damage, costs, charges and expenses caused to or suffered by or that may be caused to or suffered by MMMOCL from time to time shall be final and binding on us.
4. We undertake to pay MMMOCL any money so demanded notwithstanding any dispute or disputes raised by the Licensee in any suit or proceeding pending before any court of tribunal unequivocal, without demur. The payment so made by us under this bond shall be valid discharge of our liability for payment thereunder and the Licensee shall have no claim against us for making such payment.
5. We further agree that the Bank Guarantee herein contained shall remain in full force and effect for twelve (12) months from the date of enforcement of this Bank Guarantee. Bank Guarantee shall continue to be enforceable till all the dues of MMMOCL under or by the said Contract Agreement and Policy have been fully paid and its claims satisfied or discharged. MMMOCL needs to certify that the terms and conditions of the said Contract Agreement and Policy have been fully and properly carried out by the said Licensee to discharges this Bank Guarantee. We shall be discharged from all liability under this Bank Guarantee thereafter.
6. We further agree that MMMOCL shall have the fullest liberty without our consent and without affecting in any manner our obligations hereunder to vary any of the terms and conditions of the said License Agreement or to extend the time of performance by the said Licensee from time to time or to postpone for any time any of the powers exercisable by MMMOCL against the said Licensee and to forbear or enforce any of the terms and conditions relating to the said License Agreement and we shall not be relieved from our liability by reasons of any such variation or extension being granted to the said Licensee or for any forbearance act or omission on the part of MMMOCL or by any such matter or thing whatsoever which under the law relating to sureties would, but for this provisions, have effect of so relieving us.
7. This Bank Guarantee will not be discharged due to the change in the constitution of the Bank or the Licensee.

8. This Bank Guarantee is valid till _____ unless a suitable action to enforce the claim under this Bank Guarantee is made, all MMMOCL's rights under this Bank Guarantee shall be forfeited and we shall be relieved and discharged from all liabilities there under.
9. We undertake to continue extending the period of this Bank Guarantee by 12 months till the end of the License Period.
10. We undertake not to revoke this Bank Guarantee during its currency except with the previous consent of MMMOCL in writing.
11. The Bank Guarantee shall be payable at Mumbai. Further, the Bank Guarantee will be issued in SFMS Mode. Copy of Message with code IFN 760 COV Bank Guarantee Message shall be attached along with the Bank Guarantee as confirmation.

Dated this _____ day of _____ 2024

FOR & ON BEHALF OF BANK

The above guarantee is accepted
For and on behalf of MMMOCL (Name & Designation)

Note: As per RBI guidelines, Bank Guarantee should be issued by the issuing bank through SFMS mode. For the purpose, the bank details in respect of MMMOCL for opening Bank Guarantee through SFMS mode are as follows:

Bank Name - State Bank of India

Govt Colony, Bandra (East)

Mumbai- 400051

Account No. 39579947249

IFSC: SBIN0003838

MICR: 400002031

Confirmation of the Bank Guarantee from MMMOCL's Bank will be obtained by Licensee and submitted along with the Bank Guarantee.

For Bank Guarantee / Demand Draft / Bankers Cheque

- Any bank which features in the latest scheduled commercial bank list published by the RBI is permissible except Axis Bank for performance security furnishing in form of Bank Guarantee.

Bank Name - State Bank of India

Govt Colony, Bandra (East)

Mumbai- 400051

Account No. 39579947249

IFSC: SBIN0003838

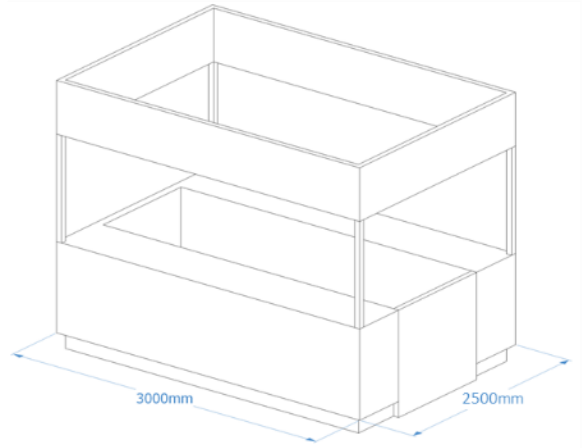
MICR: 400002031

Annexure 9: Design Guidelines

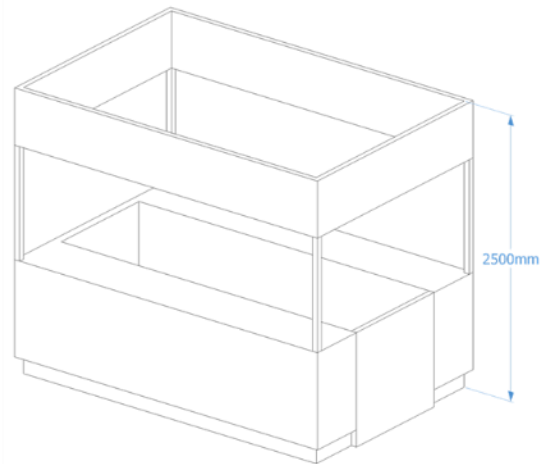
A. Guidelines for Kiosk Design Criteria

1. Kiosk Size

- i. Total footprint (length & breadth) of the kiosk: 3m x 2.5m.
- ii. No projections of any sort outside the designated area is permitted.



- iii. The total height of the kiosk should be shall be 2.5m.



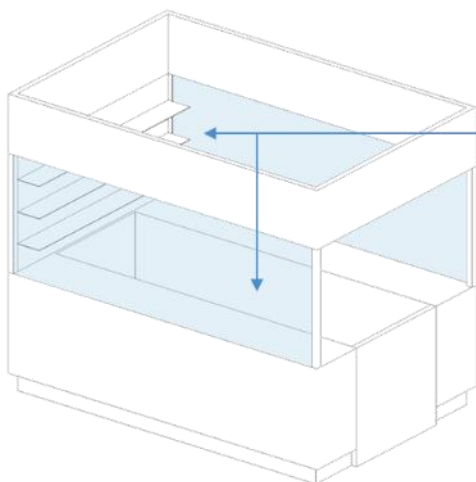
- iv. The spillover area is 1.5m wide from all sides of the kiosk except when located along a wall or abutting another kiosk.



Reason: To maintain the same volume and same visual language for all the kiosks at the station.

2. Kiosk Design

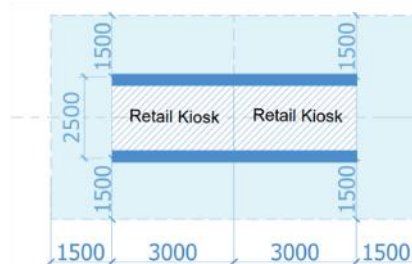
i. The counter top fixtures should not obstruct the sight lines within the station.



Two sides of the kiosk should be kept free of obstruction (■).

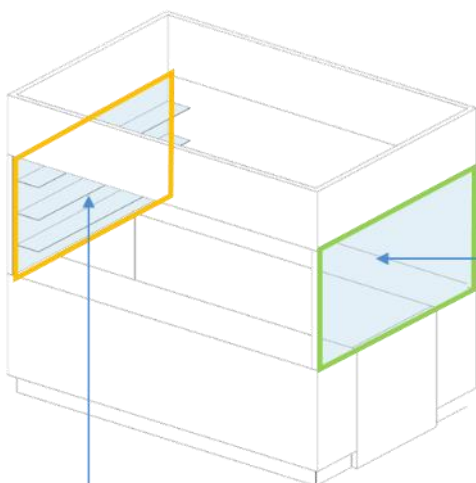


Image for reference purpose only



Reason: To maintain visual connectivity within the station on the free sides of the kiosk.

ii. The shorter sides of the kiosks can be used for display of merchandise.



The free shorter side of the kiosk can be used for display of merchandise given that it is covered with a glass backdrop to maintain light of sight within the station (■).

The side common with the adjacent kiosk can be used for display of merchandise and can be of opaque nature (■).



Image for reference purpose only



Reason: To maintain the same visual language for all the kiosks at the station.

iii. The counter top fixtures should not obstruct the sight lines within the station.

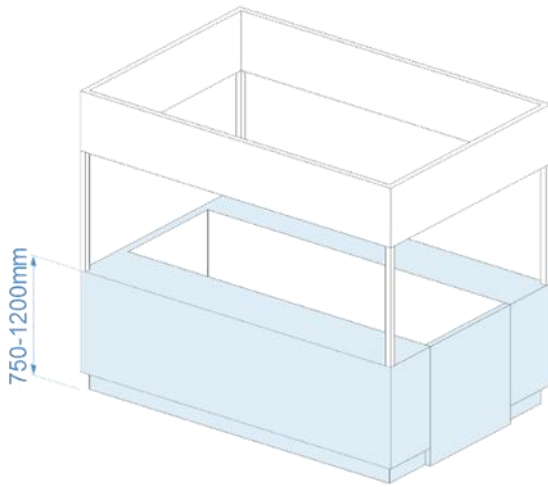
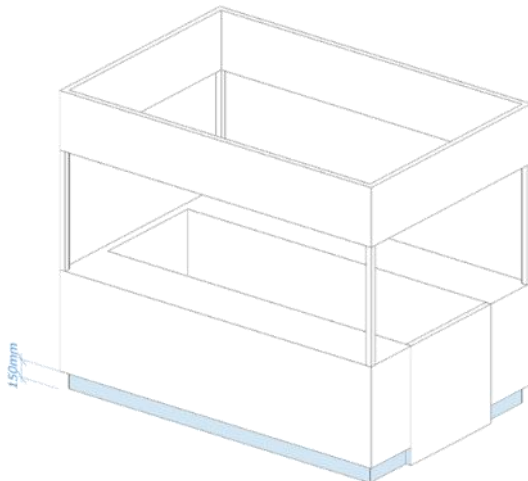


Image for reference purpose only

Reason: To maintain the same counter height w.r.t. all the kiosks at the station.

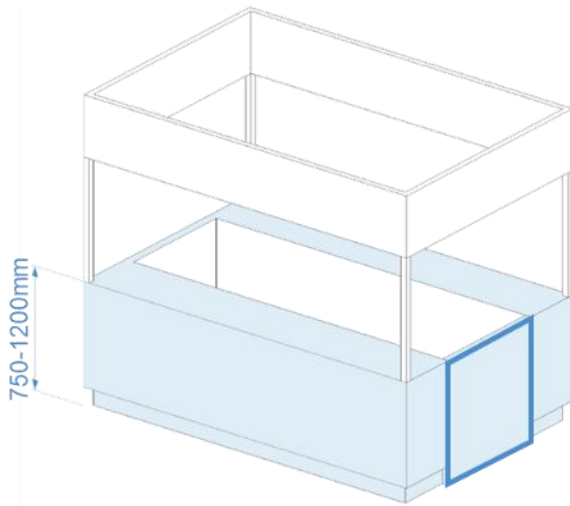
iv. All Kiosks to have a minimum 150mm high toe kick base used along all storefront display/ counter area.



Images for reference purpose only

Reason: To create a recess for one's feet, which allows one to stand closer to the countertop and also allows for easy cleaning and maintenance along the edges.

v. Entry gate is to be designed to appear as a continuous element of the Kiosk casework.



Images for reference purpose only

Reason: To maintain the same visual language for all the elements that make up the Kiosk casework.

vi. The counter front can be used for display and storage if required by the kiosk tenant.

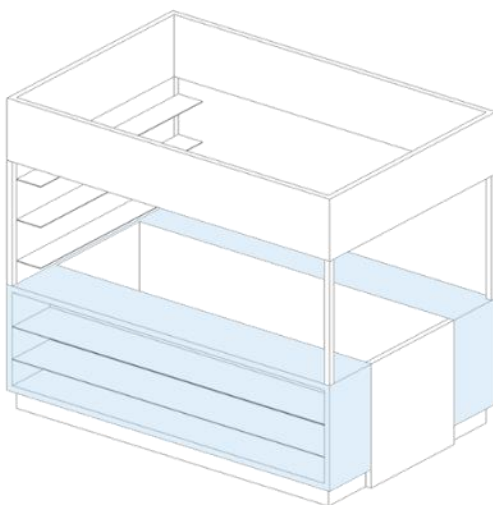
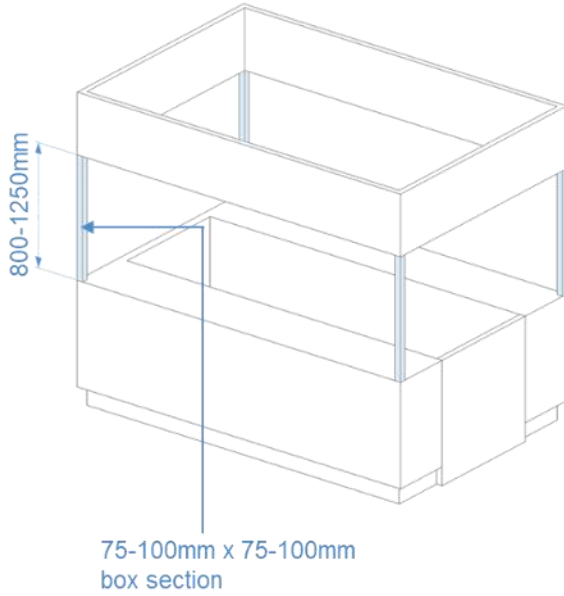


Image for reference purpose only

Reason: To maintain the same location for display and storage.

vii. Height of post supporting overhead structure should be in the range of 800-1250mm only on all sides.



Images for reference purpose only

Reason: To maintain the same support post height and size w.r.t. all the kiosks at the station.

viii. The height of the overhead structure should be 500mm only. Overhead structures should be utilised for signage and lighting.

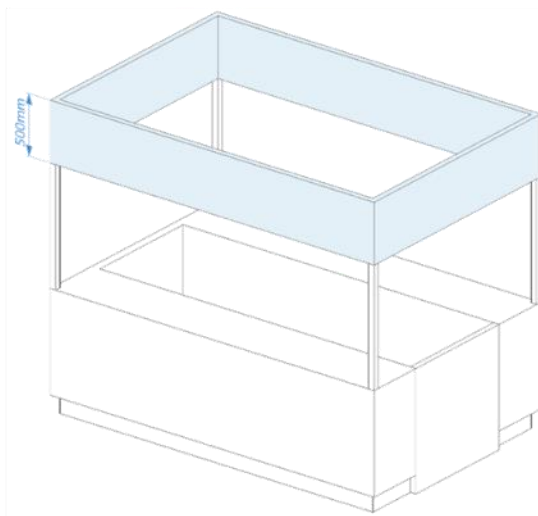


Image for reference purpose only

Reason: To maintain the same overhead structure height w.r.t. all the kiosks at the station.

ix. The space at top of the overhead structure may be used for storage as required by the kiosk tenant.

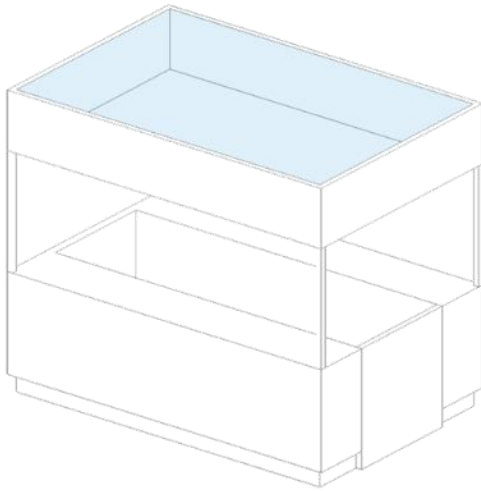


Image for reference purpose only

Reason: To provide extra storage space if required by the kiosk tenant.

--- INTENTIONALLY LEFT BLANK ---

3. Counter Display

- i. Point of Sale (POS) must be recessed into the counter or shrouded such that the majority of the POS is hidden from view and out of reach of the commuters.
- ii. All controls, adjustments, or access points to display cases shall be out of reach of commuters.
- iii. Item storage should not be exposed.
- iv. All cabinets and drawers must be lockable.

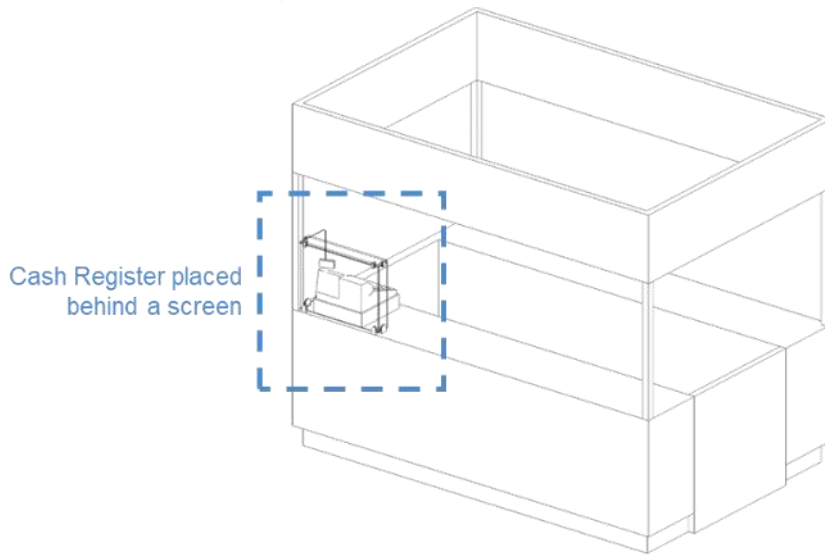


Image for reference purpose only

Reason: To safeguard the point of sale equipment.

4. Materials to be used for the kiosk

- i. The material should conform to food and fire safety standards.
- ii. Kiosk Tenants must utilize materials that are upscale in quality, resist wear and dirt penetration and are easily maintained, meeting IS code requirements.
- iii. Materials selected should provide a complementary backdrop for the merchandise being offered.
- iv. A list acceptable materials includes (not an exhaustive list):

Counter Tops:



Metal - stainless or painted steel, brass, copper, aluminum



Acrylic Sheets

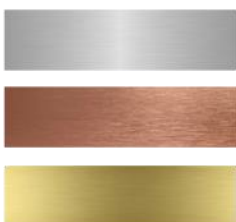


Glass



MDF + baking paint finish

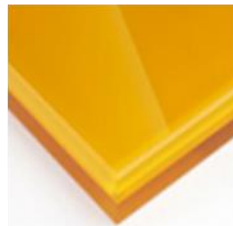
Counter Front:



Metal - stainless or painted steel, brass, copper, aluminum



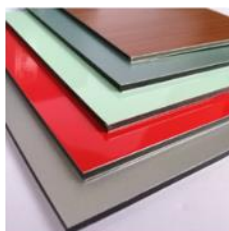
Acrylic Sheets



Glass



MDF + baking paint finish



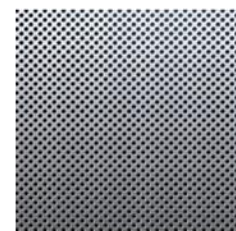
Aluminum Composite Plastic Panels



High Pressure Laminates



Vinyl Material



Perforated Metal

Images for reference purpose only

Reason: To guide a similar material palette across all kiosks at the station to maintain a similar visual language.

SOME MATERIALS WHICH ARE NOT PERMITTED (not an exhaustive list):



Low Pressure
Laminates



Painted drywall



Untreated wood/
plywood

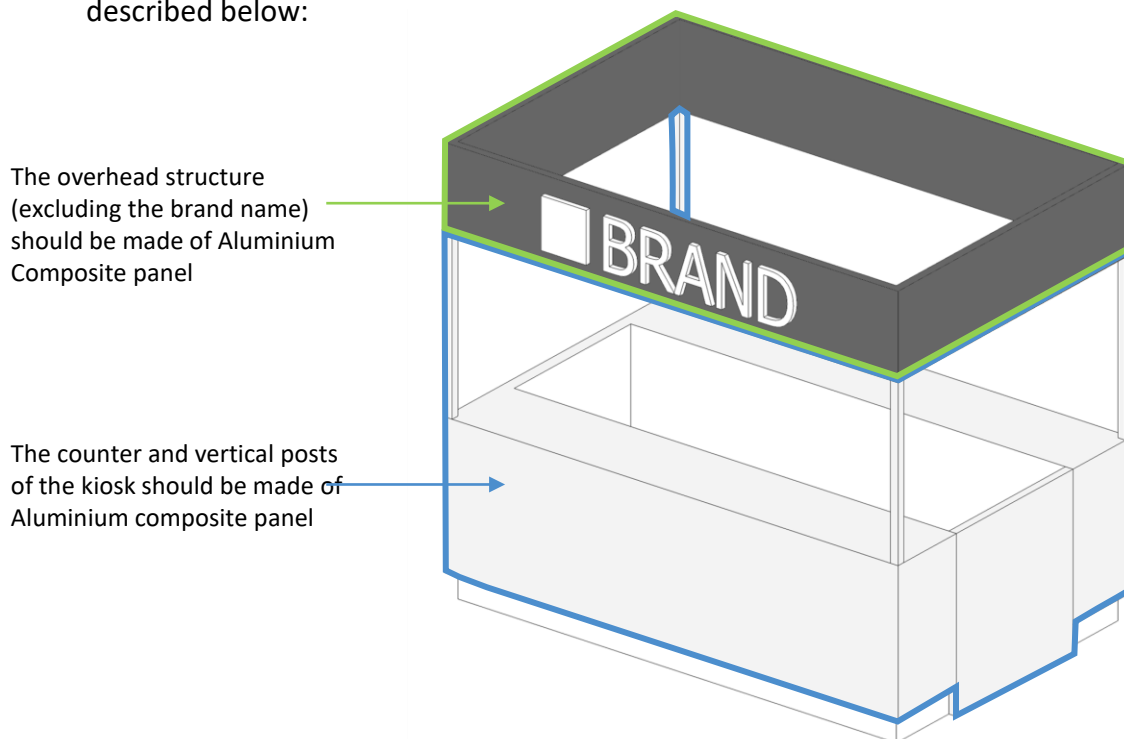
Images for reference purpose only

Reason: To make sure materials which are non-durable and do not conform to food and fire safety standards are avoided.

INTENTIONALLY LEFT BLANK

Materials to be used for the kiosk

1. Kiosk tenants must utilise materials that are upscale in quality, resist wear and dirt penetration and are easily maintained, meeting IS code requirements of food and fire safety.
2. Glass can be used wherever the merchandise is being displayed.
3. The kiosk should be clad with Aluminium Composite Panels (ACP) as described below:



Images for reference purpose only

5. Alternate design options for kiosk depending on the use

The elements highlighted in colour are to strictly adhere to the kiosk guidelines mentioned in this document.

OPTION 1-CLOSED KIOSK LAYOUT

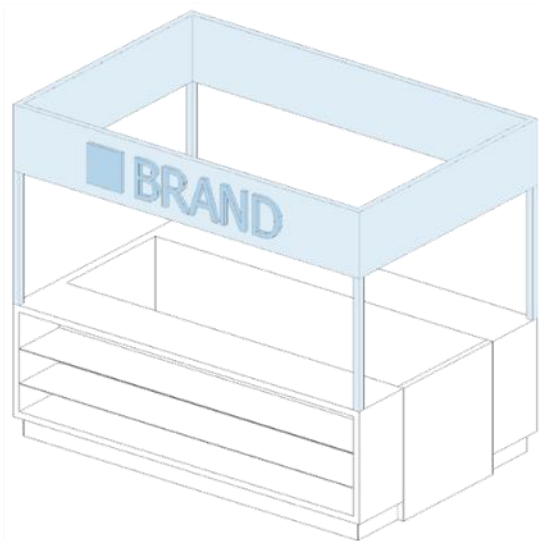


Image for reference purpose only

OPTION 2-PARTIALLY OPEN/ WALKTHROUGH KIOSK LAYOUT

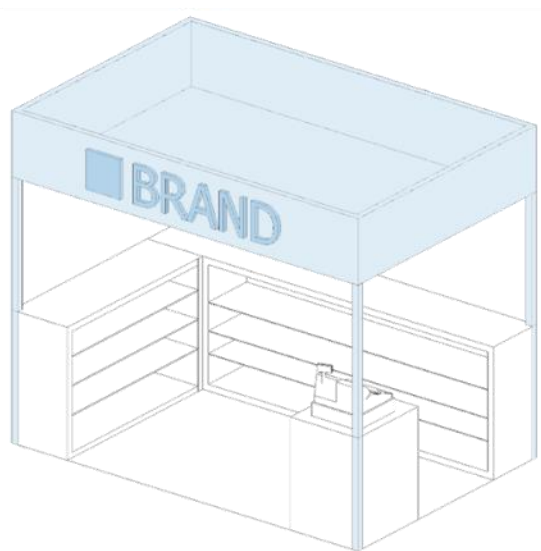


Image for reference purpose only

The elements highlighted in colour are to strictly adhere to the kiosk guidelines mentioned in this document.

OPTION 3-OPEN/ WALKTHROUGH KIOSK LAYOUT

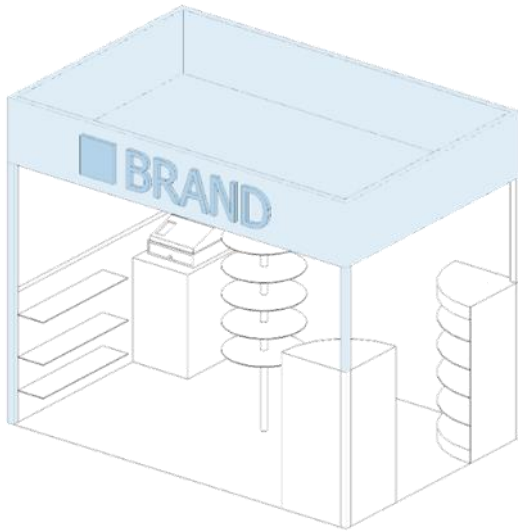


Image for reference purpose only

Reason: To make sure similar visual language is followed for all the kiosks at the station.

--- INTENTIONALLY LEFT BLANK ---

6. Signage

i. The brand signage location should be only on the overhead structure for all kiosks to maintain similar visual language. However, the alignment of the text can be up to the kiosk tenant.

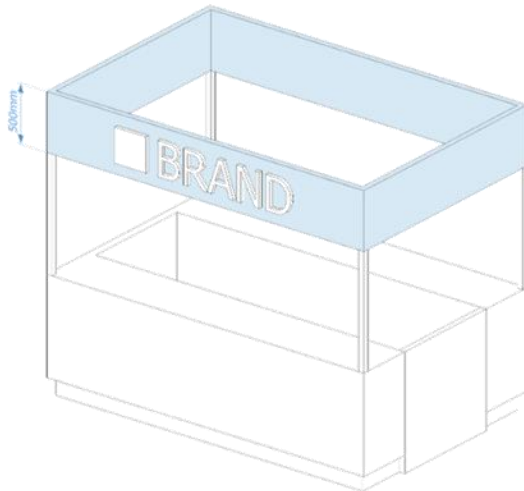


Image for reference purpose only

Reason: To make sure location of brand signage is same across all kiosks at the station.

ii. Depending on the sign design, letters will be restricted to an average height of 200mm in most cases with any given letter not to exceed 300mm in total height.

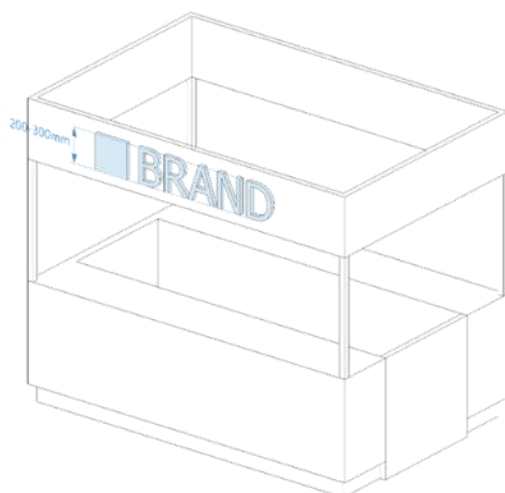


Image for reference purpose only

Reason: To make sure size of brand signage is same across all kiosks at the station.

iii. The counter front and top can be utilized to place advertisements and menu boards as per the choice of the kiosk owner.

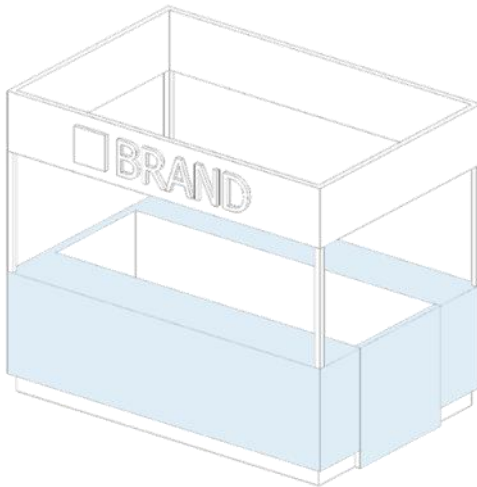


Image for reference purpose only

Reason: To maintain the same location for advertisements and menu boards across all kiosks at the station.

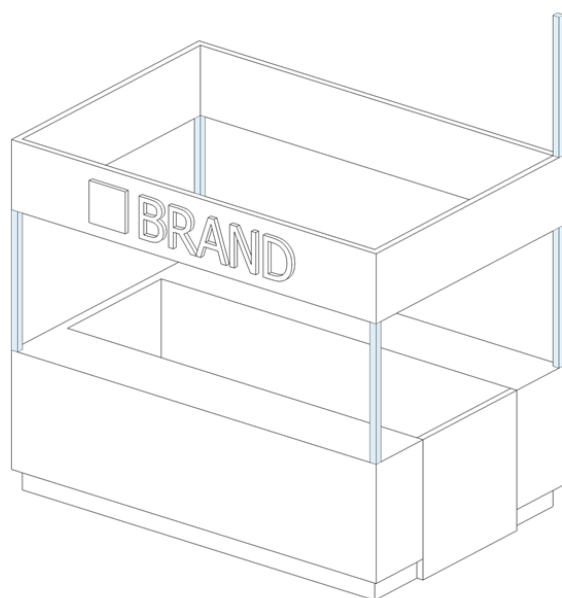
THINGS NOT ALLOWED FOR THE SIGNAGE:

- No animated signs (signs containing anything swinging, rotating, flashing, blinking), including any moving electronic message boards are permitted.
- No exposed fastenings, switches, wiring, manufacturer's /underwriter's labels. All must be out of view from the public eye.

B. Guidelines for Operational Considerations of the Kiosk

1. Electrical

- i. All showcase lighting to be incorporated into the showcase and should be free of any exposed wiring.
- ii. Lighting source should be shielded and should be directed towards the product.
- iii. Material of the display cases should be heat resistant in case of heat gain due to the lighting fixtures.
- iv. The electrical fixtures used should conform to their respective IS Codes.
- v. Absolutely no power cords or antennae may be visible.



1. One of the support post to be taken up to the bottom of the false ceiling level at the respective station since electricity for the kiosks will be sourced from the false ceiling.
2. The box section will be used to conceal the wiring from the false ceiling to the kiosk.
3. The colour of the material used for the cladding should match with the accent colour used at the respective station.

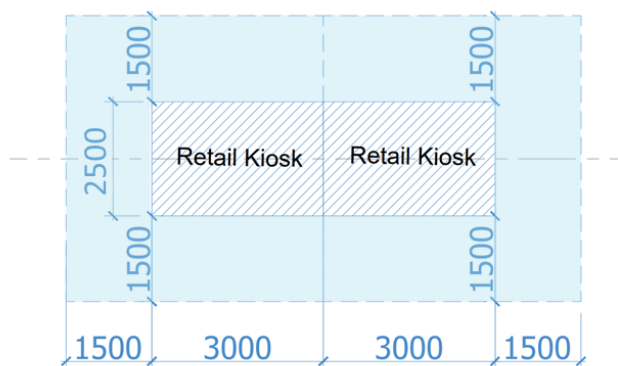
Reason: To maintain safety and hygiene standards across all the kiosks at the station.

2. Plumbing

- i. Water and sewer facilities are not available at all kiosks.

3. Management of Spillover area

- i. The maintenance and upkeep of the 1.5m wide spill over area measured from the boundary of the kiosk is responsibility of the kiosk tenant.



4. Garbage Removal

- i. The garbage bins should be hidden from public eye and should be placed within the footprint of the kiosk only.
- ii. Each kiosk tenant is responsible for removing garbage and disposing it in the appropriate bins.

Reason: To maintain safety and hygiene standards across all the kiosks at the station.



END OF DOCUMENT

Maha Mumbai Metro Operation Corporation Limited (MMMOCL)
2nd Floor, NAMTTRI Building, Adjoining New MMRDA Building,
Bandra Kurla Complex, Bandra East, Mumbai 400051
www.mmmoocl.co.in